

TR10A136 RE / 06.2012

**DE****Anleitung für Montage, Betrieb und Wartung**

Schiebetorantrieb

**EN****Instructions for Fitting, Operating and Maintenance**

Sliding Gate Operator

**FR****Instructions de montage, d'utilisation et de maintenance**

Motorisation de portail coulissant

**NL****Montage-, bedienings- en onderhoudshandleiding**

Schuifhekaandrijving

**IT****Istruzioni per il montaggio, l'uso e la manutenzione**

Motorizzazione per cancelli scorrevoli

**ES****Instrucciones de montaje, funcionamiento y mantenimiento**

Automatismo para cancela corredera

**PT****Instruções de montagem, funcionamento e manutenção**

Automatismo para portas de correr

**DEUTSCH ..... 6**  
**ENGLISH ..... 26**  
**FRANÇAIS ..... 46**  
**NEDERLANDS ..... 67**  
**ITALIANO ..... 87**  
**ESPAÑOL ..... 108**  
**PORTUGUÊS ..... 129**



..... 150

**A**

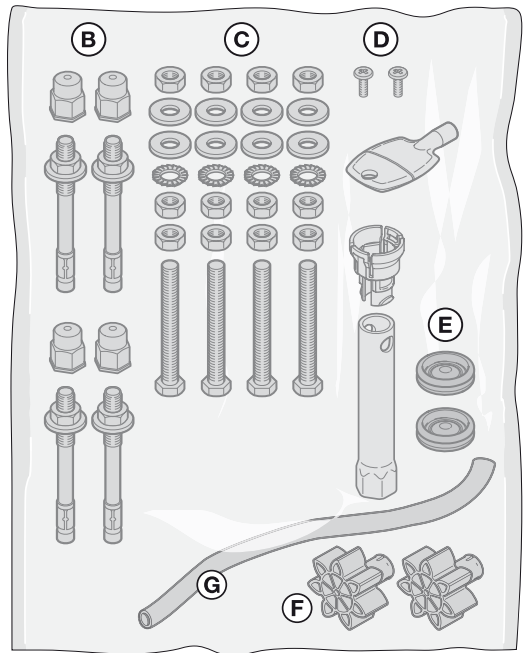
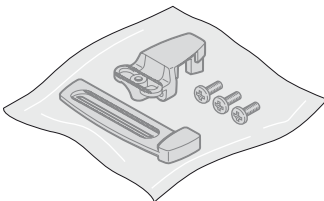
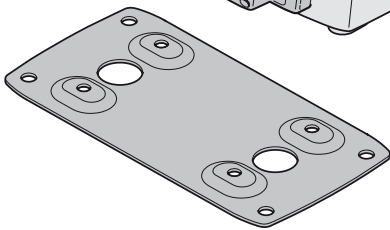
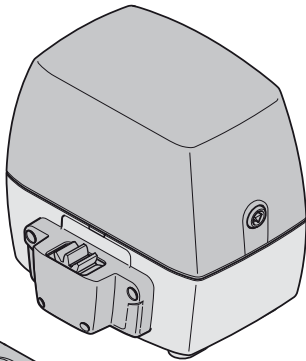
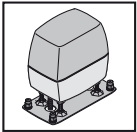
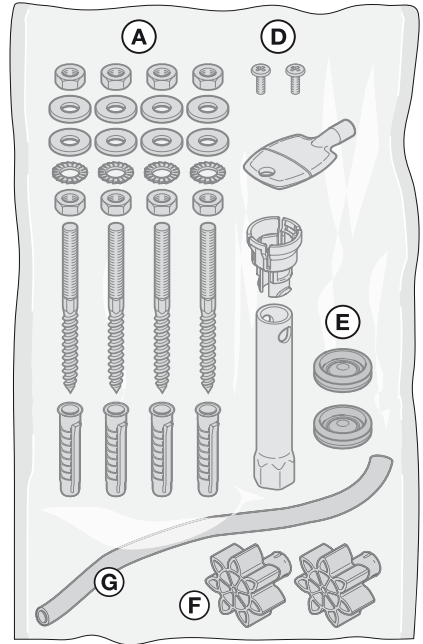
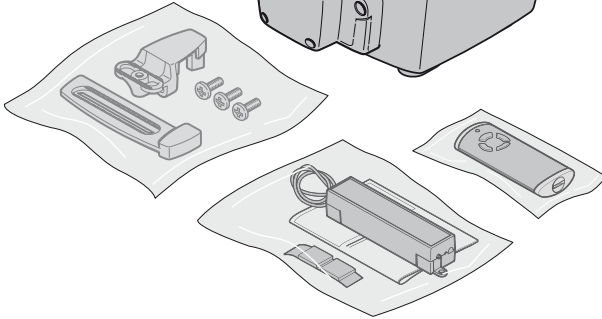
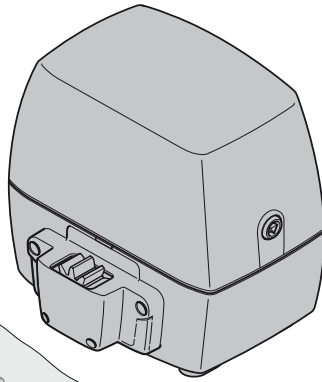
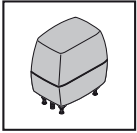

**B**

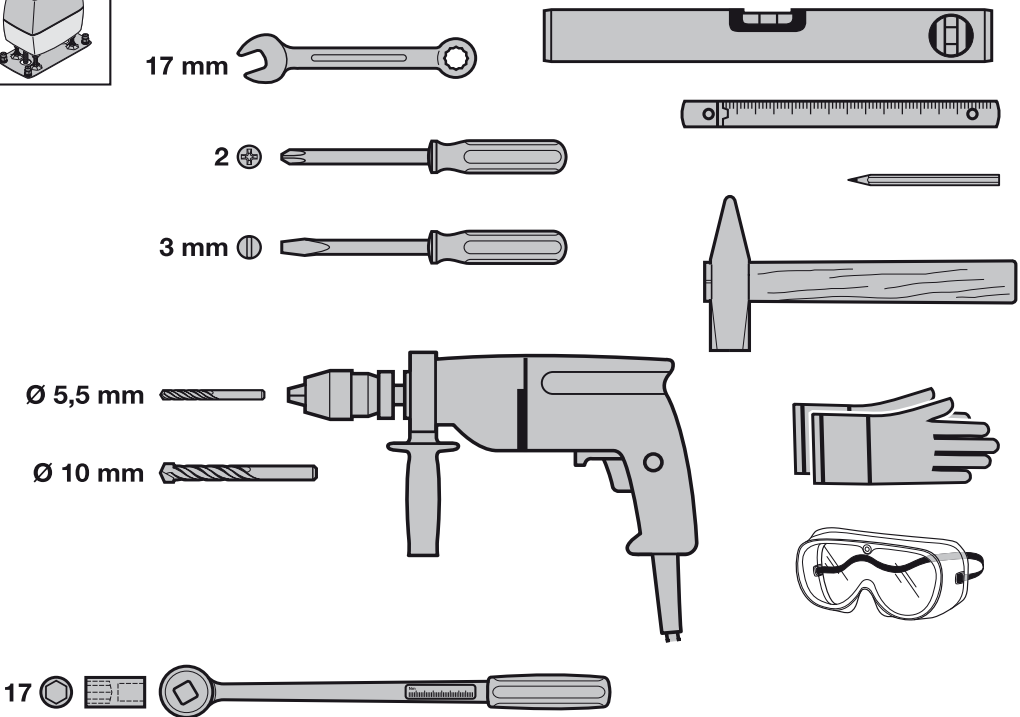
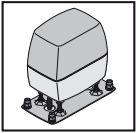
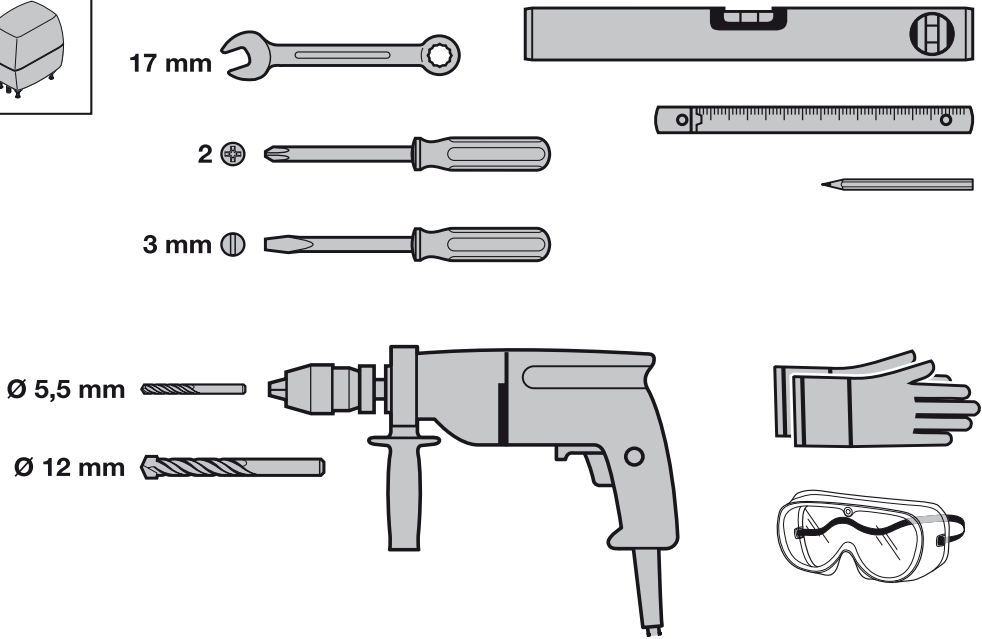
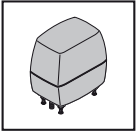



**C<sub>1</sub>**



**C<sub>2</sub>** 438 632

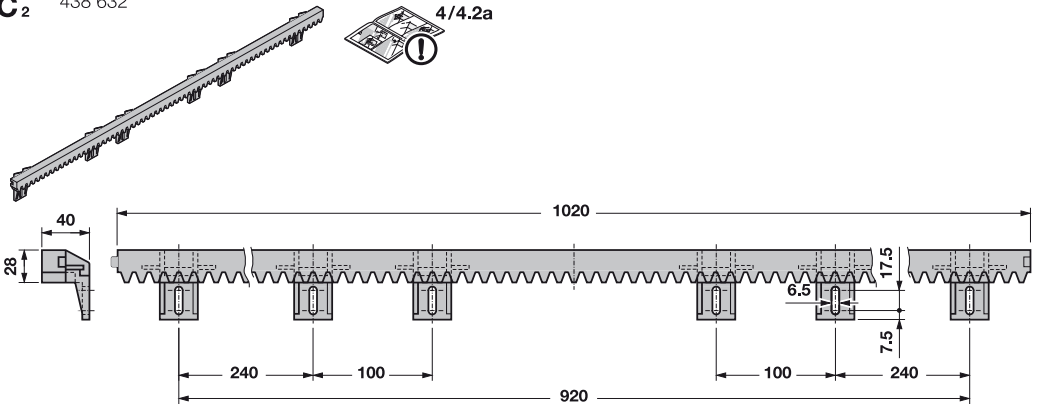

**C<sub>3</sub>** 438 631

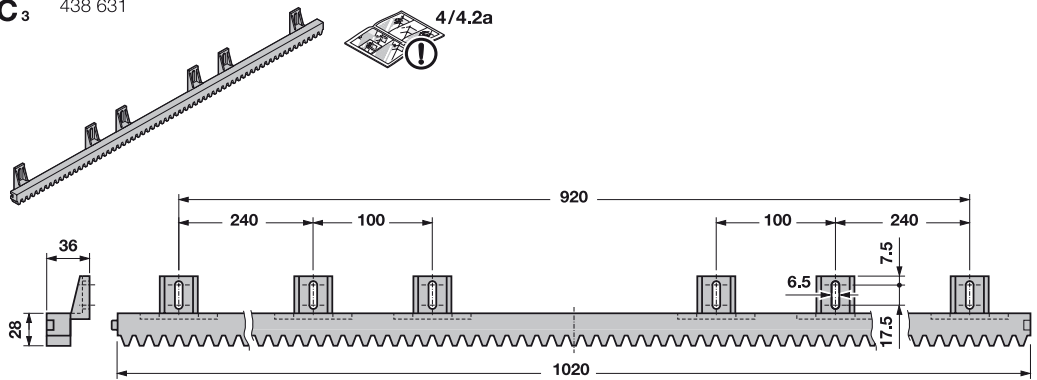

**C<sub>4</sub>** 436 444 B = 8  
438 759 B = 12

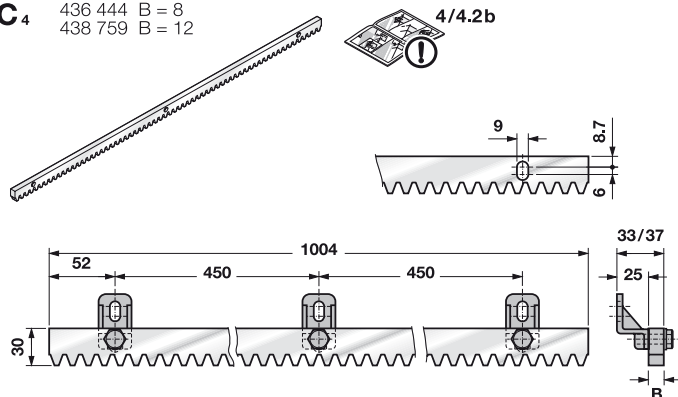

**C<sub>5</sub>** 438 765

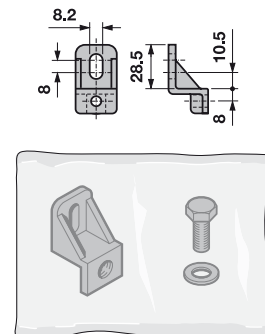

## Table of Contents

<b>A</b>	<b>Articles supplied</b> .....	<b>3</b>
<b>B</b>	<b>Tools needed for fitting the sliding gate operator</b> .....	<b>4</b>
<b>C<sub>1</sub></b>	<b>Fitting accessories for the plastic toothed tracks</b> .....	<b>5</b>
<b>C<sub>2</sub></b>	<b>Plastic toothed track with steel core (fitting bracket at bottom)</b> .....	<b>5</b>
<b>C<sub>3</sub></b>	<b>Plastic toothed track with steel core (fitting bracket at top)</b> .....	<b>5</b>
<b>C<sub>4</sub></b>	<b>Galvanized steel toothed track</b> .....	<b>5</b>
<b>C<sub>5</sub></b>	<b>Fitting accessories for steel toothed tracks</b> .....	<b>5</b>
	<b>Drill stencil</b> .....	<b>169</b>
<b>1</b>	<b>About These Instructions</b> .....	<b>27</b>
1.1	Further applicable documents .....	27
1.2	Warnings used .....	27
1.3	Definitions used .....	27
1.4	Symbols used .....	27
1.5	Abbreviations used .....	28
1.6	Information on the illustrated section .....	28
<b>2</b>	<b>⚠ Safety Instructions</b> .....	<b>28</b>
2.1	Intended use .....	28
2.2	Inappropriate use .....	28
2.3	Fitter qualification .....	28
2.4	Safety instructions for fitting, maintenance, repairs and disassembly of the gate system .....	28
2.5	Safety instructions for fitting .....	29
2.6	Safety instructions for initial start-up and for operation .....	29
2.7	Safety instructions for using the hand transmitter ..	29
2.8	Approved safety equipment .....	29
<b>3</b>	<b>Fitting</b> .....	<b>29</b>
3.1	Inspecting and preparing the gate/gate system .....	29
3.2	Fitting the sliding gate operator .....	30
3.3	Fitting the toothed track .....	30
3.4	Sliding gate operator electrical connection .....	31
3.5	Fitting the circuit board bracket .....	31
3.6	Fitting the magnet holder .....	31
3.7	Locking the operators .....	31
3.8	Connecting additional components/accessories ..	31
<b>4</b>	<b>Initial operation</b> .....	<b>32</b>
4.1	Preparation .....	33
4.2	Teaching in the gate's end-of-travel positions .....	33
4.3	Learning the forces .....	33
4.4	Changing the starting point for slow speed when opening and closing .....	34
4.5	Reversal limit .....	35
4.6	Automatic timed closing .....	35
<b>5</b>	<b>DIL Switch Functions</b> .....	<b>35</b>
5.1	DIL switch 1 .....	35
5.2	DIL switch 2 .....	35
5.3	DIL switch 3/DIL switch 4 .....	35
5.4	DIL switch 5/DIL switch 6 .....	36
5.5	DIL switch 7 .....	36
5.6	DIL switch 8/DIL switch 9 .....	36
5.7	DIL switch 10 .....	36
5.8	DIL switch 11 .....	36
5.9	DIL switch 12 .....	36
5.10	DIL switch 13 .....	36
5.11	DIL switch 14 .....	37
5.12	DIL switch 15 .....	37
5.13	DIL switch 16 .....	37

<b>6</b>	<b>Radio</b> .....	<b>37</b>
6.1	Hand transmitter HS 4 BiSecur .....	37
6.2	Radio receiver .....	39
<b>7</b>	<b>Final Work</b> .....	<b>39</b>
7.1	Fixing the warning sign .....	39
<b>8</b>	<b>Operation</b> .....	<b>39</b>
8.1	Instructing users .....	39
8.2	Function check .....	39
8.3	Normal operation .....	40
8.4	Behaviour during a power failure .....	40
8.5	Behaviour following a power failure .....	40
<b>9</b>	<b>Inspection and Maintenance</b> .....	<b>40</b>
<b>10</b>	<b>Displays for Operating Conditions, Errors and Warnings</b> .....	<b>40</b>
10.1	LED GN .....	40
10.2	LED RT .....	40
10.3	Display of error and warning messages .....	40
10.4	Error acknowledgement .....	41
<b>11</b>	<b>Resetting the Control/Restoring Factory Settings</b> .....	<b>41</b>
<b>12</b>	<b>Dismantling and Disposal</b> .....	<b>41</b>
<b>13</b>	<b>Optional Accessories</b> .....	<b>41</b>
<b>14</b>	<b>Warranty Conditions</b> .....	<b>42</b>
<b>15</b>	<b>Excerpt from the Declaration of Incorporation</b> ..	<b>42</b>
<b>16</b>	<b>Technical Data</b> .....	<b>43</b>
<b>17</b>	<b>Overview of DIL Switch Functions</b> .....	<b>44</b>



**Illustrated section** .....

**150**

Dissemination as well as duplication of this document and the use and communication of its content are prohibited unless explicitly permitted. Noncompliance will result in damage compensation obligations. All rights reserved in the event of patent, utility model or design model registration. Subject to changes.

Dear Customer,

We are delighted that you have decided to choose a quality product from our company.

## 1 About These Instructions

These instructions are **original operating instructions** as outlined in the EC Directive 2006/42/EC. Read through all of the instructions carefully, as they contain important information about the product. Pay attention to and follow the instructions provided, particularly the safety instructions and warnings.





Keep these instructions in a safe place for later reference!

### 1.1 Further applicable documents

The following documents for safe handling and maintenance must be provided:

- These instructions
- The enclosed test log book
- Sliding gate instructions

### 1.2 Warnings used

	The general warning symbol indicates a danger that can lead to <b>injury</b> or <b>death</b> . In the text, the general warning symbol will be used in connection with the caution levels described below. In the illustrated section, an additional instruction refers back to the explanation in the text.
 <b>DANGER</b>	Indicates a danger that leads directly to death or serious injuries.
 <b>WARNING</b>	Indicates a danger that can lead to death or serious injuries.
 <b>CAUTION</b>	Indicates a danger that can lead to minor or moderate injuries.
<b>ATTENTION</b>	Indicates a danger that can lead to <b>damage</b> or <b>destruction of the product</b> .

### 1.3 Definitions used

#### Hold-open phase

Waiting phase at the *OPEN* end-of-travel position or partial opening before the gate closes during automatic timed closing.

#### Automatic timed closing

Automatic timed closing of the gate after a set time has elapsed and after reaching the *OPEN* end-of-travel position or partial opening.

#### DIL switches

Switches on the control circuit board for setting the control.

#### Through-traffic photocell

When the gate is passed through, the photocell shortens the hold-open phase and the gate closes a short time thereafter.

#### Impulse sequence control

With each push of the button, the gate is started against the previous direction of travel, or the motion of the gate is stopped.

#### Force training run

The forces necessary for gate travel are taught in during this learning run.

#### Normal operation

Gate travel with the taught-in travel distances and forces.

#### Reference run

Gate travel towards the *CLOSE* end-of-travel position in order to set the home position.

#### Reversing cycle/safety reversal

Gate travel in the opposite direction when the safety device or force limit is activated.

#### Reversal limit

If a safety device is activated, gate travel is triggered in the opposite direction (reverse cycle) up to the reversal limit shortly before the *CLOSE* end-of-travel position. If this limit is passed, no reversal occurs to ensure that the gate reaches the end-of-travel position without disrupting travel.

#### Slow speed

The area in which the gate moves very slowly, in order to gently move to the end-of-travel position.

#### Press-and-release operation

After an impulse is sent, the operator independently moves into the end-of-travel position.

#### Partial opening

The distance the gate is opened for pedestrian traffic.

#### Press-and-hold operation

The gate travels only as long as the respective buttons are pressed.

#### Full opening

The travel to completely open the gate.

#### Pre-warning time

The time between the travel command (impulse) and the start of travel.

#### Factory reset

Resetting the taught-in values to the delivery status/ex factory setting.

### 1.4 Symbols used

#### Symbols

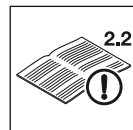

See text section

In this example, **2.2** means: see text section, section 2.2



Important note for avoiding damage to property



Check for smooth running



If necessary, see the separate fitting instructions for the emergency battery

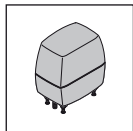

Standard sliding gate operator

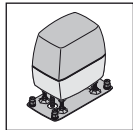

Reinforced sliding gate operator



Power failure



Restore power



Audible engagement



DIL switch factory setting

## 1.5 Abbreviations used

### Colour code for cables, single conductors and components

The abbreviations of the colours for identifying the cables, conductors and components comply with the international colour code according to IEC 757:

<b>BN</b>	Brown
<b>GN</b>	Green
<b>WH</b>	White
<b>YE</b>	Yellow

## 1.6 Information on the illustrated section

The illustrated section shows the operator fitting of an operator without a base plate to the inside right of the closed sliding gate. Where fitting or programming differs for an operator with base plate or for a sliding gate with the operator attached to the inside left of the closed sliding gate, this is shown in addition.

All dimensions in the illustrated section are in [mm].

## 2 Safety Instructions

### ATTENTION:

IMPORTANT SAFETY INSTRUCTIONS.

FOR THE SAFETY OF PERSONS, IT IS IMPORTANT TO COMPLY WITH THE FOLLOWING INSTRUCTIONS. THESE INSTRUCTIONS MUST BE KEPT.

### 2.1 Intended use

Depending on the type of operator, the operator can be used in private/non-commercial areas or in commercial areas.

The sliding door operator is exclusively intended for the operation of smooth-running sliding doors. The maximum permissible door size and maximum weight must not be exceeded. The door must be easy to open and close manually.

Note the manufacturer's specifications regarding the gate and operator combination. Potential hazards as outlined in DIN EN 13241-1 are avoided by construction and fitting according to our guidelines. Gate systems that are located in a public area and only have one protective device, such as a force limit, may only be operated under supervision.

### 2.2 Inappropriate use

Continuous operation and use on gates with a gradient or slope is not permitted.

### 2.3 Fitter qualification

Only correct fitting and maintenance in compliance with the instructions by a competent/specialist company or a competent/qualified person ensures safe and flawless operation of the system. According to EN 12635, a specialist is a person with suitable training, specialist knowledge and practical experience sufficient to correctly and safely fit, test, and maintain a gate system.

### 2.4 Safety instructions for fitting, maintenance, repairs and disassembly of the gate system

#### WARNING

#### Danger of injury due to a malfunction in the gate system

► See warning in section 3.1

#### WARNING

#### Danger of injury due to unexpected gate travel

► See warning in section 9



Fitting, maintenance, repairs, and disassembly of the gate system and sliding gate operator must be performed by a specialist.

► In the event of a gate system or gate operator failure (sluggish operation or other malfunctions), a specialist must be commissioned immediately for the inspection/repair work.

## 2.5 Safety instructions for fitting

The specialist carrying out the work must ensure that installation is conducted in compliance with the prevailing national job safety rules and regulations and those governing the operation of electrical equipment. The relevant national directives must be observed. Potential hazards as outlined in DIN EN 13241-1 are avoided by construction and fitting according to our guidelines.

After fitting has been completed, the installer of the gate system must declare conformity with DIN EN 13241-1 in accordance with the scope of application.

	 <b>DANGER</b>
	<b>Mains voltage</b>
▶ See warning in section 3.4	

 <b>WARNING</b>
<b>Danger of injury due to unwanted gate travel</b>
▶ See warning in section 3.2
▶ See warning in section 3.8

 <b>WARNING</b>
<b>Unsuitable fixing material</b>
▶ See warning in section 3.2.3

## 2.6 Safety instructions for initial start-up and for operation

 <b>WARNING</b>
<b>Danger of injury during gate travel</b>
▶ See warning in sections 4 and 8
<b>Danger of crushing and shearing</b>
▶ See warning in sections 4 and 8

 <b>CAUTION</b>
<b>Danger of injury due to the force value being set too high</b>
▶ See warning in section 4.3.1

## 2.7 Safety instructions for using the hand transmitter

 <b>WARNING</b>
<b>Danger of injury due to unwanted gate travel</b>
▶ See warning in section 6.1

 <b>CAUTION</b>
<b>Danger of injuries due to unintended gate travel</b>
▶ See warning in section 6

## 2.8 Approved safety equipment

Safety relevant functions or components of the control, such as the force limit, external photocells and closing edge safety device, have been designed and approved in accordance with category 2, PL "c" of EN ISO 13849-1:2008.

 <b>WARNING</b>
<b>Danger of injuries due to faulty safety equipment</b>
▶ See warning in section 4.6

### 2.8.1 Safety information on compliance with the operating forces

If you observe these instructions, **as well as** the following conditions, you can assume that the operating forces are complied with according to DIN EN 12453:

- The centre of gravity for the gate must be in the centre of the gate (maximum permissible deviation  $\pm 20\%$ ).
- The gate is easy to move and does not have any gradients/slopes (0%).
- A Hörmann sound-absorbing seal DP 3 is fitted to the closing edge(s). This must be ordered separately (article no.: 436 388).
- The operator is programmed for slow speed (see section 4.3.2).
- The reversal limit at 50 mm opening width has been checked and maintained over the entire length of the main closing edge.
- The distance between the supporting rollers in self-supporting gates (maximum width 6200 mm, maximum opening width 4000 mm) is max. 2000 mm.

## 3 Fitting

### ATTENTION:

IMPORTANT INSTRUCTIONS FOR SAFE INSTALLATION. OBSERVE ALL INSTRUCTIONS, INCORRECT FITTING COULD RESULT IN SERIOUS INJURY.

### 3.1 Inspecting and preparing the gate/gate system

 <b>WARNING</b>
<b>Danger of injury due to a malfunction in the gate system</b>
A malfunction in the gate system or an incorrectly aligned gate can cause serious injury
▶ Do not use the gate system if repair or adjustment work must be conducted.
▶ Check the entire gate system (joints, gate bearings and fastenings) for wear and possible damage.
▶ Check for signs of rust, corrosion or fractures.

The sliding gate operator is not designed for operation with sluggish gates, that is, gates that can no longer be opened or closed manually, or can only be opened/closed manually with difficulty.

The operator is only designed for use with gates that do not have any gradient or slope.

The gate must be in a flawless mechanical condition, so that it can be easily operated by hand (EN 12604).

## ENGLISH

- ▶ Check whether the gate can be opened and closed correctly.
- ▶ Immobilize any mechanical locks not needed for power operation of the sliding gate. This includes in particular any locking mechanisms connected with the gate lock.
- ▶ Mechanically secure the gate to prevent it from running out of its guides.
- ▶ **Change to the illustrated section for the fitting and initial operation. Observe the respective text section when you are prompted to by the symbol for the text reference.**

### 3.2 Fitting the sliding gate operator

#### WARNING

##### Danger of injury due to unwanted gate travel

Incorrect assembly or handling of the operator may trigger unwanted gate travel that may result in persons or objects being trapped.

- ▶ Follow all the instructions provided in this manual.

#### 3.2.1 Foundation

#### ATTENTION

##### Malfunctions in the connection cables

Malfunctions may occur if connection cables and supply lines are ducted together.

- ▶ Duct the operator's connection cables (24 V DC) in an installation system that is separate from supply lines (230/240 V AC).

1. A foundation must be laid (see **Figure 1a/1b**). The  mark represents the frost-free depth (in Germany = 80 cm).  
A larger foundation must be laid if using a closing edge safety device (see **Figure 1c/1d**).
2. Concrete  $\geq$  B25/C25 (compacted) must be used with the operator type with base plate.
3. A base foundation may be required for gates with inside rollers.
4. The 230/240 V AC mains lead must be routed through a tube in the foundation. The lead to connect 24 V accessories must be installed in a tube that is separated from the mains lead (see **Figure 1.1**).

#### NOTE:

The foundation must have **set and dried sufficiently** before the following work is carried out.

#### 3.2.2 Establishing the fitting dimensions

1. Mark the drill position of the four drill holes on the surface of the foundation.  
Depending on the operator, use:
  - The drill stencil at the back of these instructions for  $\varnothing$  12 mm holes with stock screws (see **Figure 2a**).
  - The base plate for  $\varnothing$  10 mm holes with heavy-duty anchors (see **Figure 2b**).
2. Select the toothed track to be used from the table below and find the minimum and maximum fitting dimensions (dimension A).

Toothed track	Dimension A (mm)	
	Min.	Max.
436 444	124	136
438 759	126	138
438 631	125	129
438 632	129	133

#### 3.2.3 Fixing

- ▶ See **Figures 2a.1/2b.1**

#### WARNING

##### Unsuitable fixing material

Use of unsuitable fixing material may mean that the operator is insecurely attached and could come loose.

- ▶ Only use the provided fixing material in concrete  $\geq$  B25/C25 (see **Figures 1.1/2.1**).

#### ATTENTION

##### Damage caused by dirt

Drilling dust and chippings can lead to malfunctions.

- ▶ Cover the operator during drilling work.

- ▶ After drilling, check the depth of the hole.

Hole	Depth
$\varnothing$ 12 mm for stock screws	80 mm
$\varnothing$ 10 mm for heavy-duty anchors	105 mm

- ▶ Use the socket wrench included in the scope of delivery to install the stock screws.

#### 3.2.4 Fitting the operator housing

- ▶ See **Figures 3 – 3.5**

#### ATTENTION!

##### Damage due to moisture

- ▶ Protect the control from moisture when you open the operator housing
- ▶ Open the operator housing, release the operator and remove the circuit board bracket.  
The motor and toothed wheel are lowered in the housing when the operator is released.
- ▶ If necessary, cut the tube seals to fit the tubes.
- ▶ When the housing is placed on the stock screws or base plate, pull the mains lead and, if necessary, the 24 V connecting lead from below through the tube seals and into the housing without any distortion.
- ▶ When tightening, pay attention that it is horizontal, stable and securely fastened.

### 3.3 Fitting the toothed track

#### Prior to fitting:

- ▶ Check that required hole depths are available.
- ▶ To fit the toothed tracks, use the connectors (bolts and nuts, etc.) from the fitting accessories (see **Figure C1** or **Figure C5**). These must be ordered separately.

**NOTE:**

- Contrary to the illustrated section, use the appropriate connectors (e.g. for timber gates use woodscrews), as well as the proper hole depths for other gate types.
- Contrary to the illustrated section, the required core hole diameter may vary depending on material thickness or strength. The required diameter may be  $\varnothing 5.0 - 5.5$  mm for aluminium and  $\varnothing 5.7 - 5.8$  mm for steel.

**Fitting:**



- ▶ See **Figures 4 – 4.3**

The sliding gate operator must be released (see **Figure 3.2**).

- ▶ When fitting the toothed tracks, make sure that the transitions between the individual toothed tracks are properly aligned to ensure smooth gate movement.
- ▶ After fitting, the toothed tracks and the toothed wheel of the operator must be aligned to each other. Both the toothed tracks and the operator housing can be adjusted to do this.  
**Incorrectly fitted or poorly aligned toothed tracks may lead to unintentional reversing. It is essential that the specified dimensions are adhered to!**
- ▶ Seal the housing to protect it from humidity and vermin (see **Figure 4.4**).

**3.4 Sliding gate operator electrical connection**

- ▶ See **Figure 4.5**

	 <b>DANGER</b>
<b>Mains voltage</b>	
Contact with the mains voltage presents the danger of a deadly electric shock.	
For that reason, observe the following warnings under all circumstances:	
<ul style="list-style-type: none"> <li>▶ Electrical connections may only be made by a qualified electrician.</li> <li>▶ The on-site electrical installation must conform to the applicable protective regulations (230/240 V AC, 50/60 Hz)!</li> <li>▶ The mains plug must be disconnected before any work is performed on the operator.</li> </ul>	

- ▶ Connect the mains voltage directly at the transformer plug terminal using the NYY underground cable.

**3.5 Fitting the circuit board bracket**

- ▶ See **Figure 4.6**

1. Fasten the circuit board bracket using the two screws loosened earlier, (D), as well as two additional screws from the scope of delivery.
2. Replace the connecting terminals.

**3.6 Fitting the magnet holder**

- ▶ See **Figure 4.7**

1. Push the gate by hand into the *CLOSE* end-of-travel position.
2. Fully preassemble the magnet slide in the centre position.
3. Fit the toothed track clip so that the magnet is offset by approx. 20 mm from the reed contact in the circuit board bracket.

**3.7 Locking the operators**



- ▶ See **Figure 5**

The operator is engaged once locked.

- ▶ Turn the mechanism back to the lock position while slightly raising the motor.

**3.8 Connecting additional components/accessories**

- ▶ See the control print overview in **Figure 6**

	<b>WARNING</b>
	<p><b>Danger of injury due to unwanted gate travel</b></p> <p>Incorrectly attached control devices (e.g. buttons) may trigger unwanted gate travel. Persons or objects may be trapped as a result.</p> <ul style="list-style-type: none"> <li>▶ Install control devices at a height of at least 1.5 m (out of the reach of children).</li> <li>▶ Fit permanently installed control devices (such as buttons, etc.) within sight of the gate, but away from moving parts.</li> </ul> <p>Persons or objects may be trapped if the installed safety equipment fails.</p> <ul style="list-style-type: none"> <li>▶ In accordance with BGR 232, install at least one clearly visible and easily accessible emergency command unit (emergency OFF) near the gate so the gate can be brought to a standstill in the case of danger (see section 3.8.3)</li> </ul>

**ATTENTION****Damage to the electronics caused by external voltage**

External voltage on the connecting terminals of the control will destroy the electronics.

- ▶ Do not apply any mains voltage (230/240 V AC) to the connecting terminals of the control.

The total consumed current may be **max. 500 mA** when connecting accessories at the following terminals:

- 24 V=
- Ext. radio
- SE3/LS
- SE1/SE2

**3.8.1 Connecting an external radio receiver \***

- ▶ See **Figure 6.1**

- ▶ Connect the wires of the external radio receiver as follows:

- GN to terminal 20 (0 V)
- WH to terminal 21 (channel 1 signal)
- BN to terminal 5 (+24 V)
- YE to terminal 23 (channel 2 signal for partial opening).

or

- ▶ Insert the plug of the receiver in the corresponding socket.

\* Accessory, not included as standard equipment!



## ENGLISH

**3.8.2 Connecting an external button \***

- ▶ See **Figure 6.2**

One or more buttons with normally open contacts (volt-free), e.g. key switches, can be connected in parallel, max. lead length 10 m.

**Impulse control:**

- ▶ First contact to terminal **21**
- ▶ Second contact to terminal **20**

**Partial opening:**

- ▶ First contact to terminal **23**
- ▶ Second contact to terminal **20**

**NOTE:**

If auxiliary voltage is needed for an external button, then a voltage of +24 V DC is available for this at terminal **5** (to terminal **20** = 0 V).

**3.8.3 Connecting a cut-out to stop the operator (stop or emergency-OFF circuit)**

A cut-out with normally closed contacts (switching to 0 V or volt-free) is connected as follows (see **Figure 6.3**):

1. Remove the wire jumper inserted at the factory between terminal **12** and terminal **13**.
  - Terminal 12: STOP or emergency-OFF input
  - Terminal 13: 0 V
2. Connect the switching output or first contact to terminal **12** (STOP or emergency-OFF input).
3. Connect 0 V (ground) or the second contact to terminal **13** (0 V).

**NOTE:**

By opening the contact, any travel cycles in progress are immediately halted and permanently prevented.

**3.8.4 Connecting a warning lamp \***

- ▶ See **Figure 6.4**

A warning lamp or *CLOSE* limit switch reporting can be connected via the volt-free contacts on the *Option* connector. The voltage at the 24 V DC connector can be used for operation (e.g. warning signals prior to and during gate travel) with a 24 V lamp (max. 7 W).

**NOTE:**

A 230 V warning lamp must be directly supplied with power.

**3.8.5 Connecting safety/protective devices**

- ▶ See **Figures 6.5–6.7**

Safety devices such as photocells/closing edge safety devices (SKS) or 8k2 resistance contact strips can be connected:

SE1	in the opening direction, monitored safety device or 8k2 resistance contact strip
SE2	in the closing direction, monitored safety device or 8k2 resistance contact strip
SE3	in the closing direction, photocell without testing or dynamic 2-wire photocell, e.g. as a through-traffic photocell

The functions selected for the 3 safety circuits are set via the DIL switches (see *section 5*).

**Terminal assignment:**

Terminal <b>20</b>	0 V (power supply)
Terminal <b>18</b>	Test signal
Terminals <b>71/72/73</b>	Safety device signal
Terminal <b>5</b>	+24 V (power supply)

**NOTE:**

Safety devices without a testing unit (e.g. static photocells) must be tested twice a year. They may only be used to protect property!

**3.8.6 Connecting universal adapter print UAP 1 \***

- ▶ See **Figure 6.8**

Connection option for the universal adapter print UAP 1.

**3.8.7 Connecting HNA outdoor emergency battery \***

- ▶ See **Figure 6**

To enable gate movement in the event of a mains failure, an optional emergency battery can be connected. In the case of a mains failure, the system automatically switches to battery operation.

**⚠ WARNING****Danger of injury due to unexpected gate travel**

Unexpected gate travel can result when the emergency battery is still connected despite the mains plug being pulled out.

- ▶ Pull out the mains plug **and** the plug of the emergency battery when performing all work on the gate system.

**4 Initial operation****⚠ WARNING****Danger of injury during gate travel**

If people or objects are in the area around the gate while the gate is in motion, this can lead to injuries or damage.

- ▶ Make sure that children are not playing near the gate system.
- ▶ Make sure that no persons or objects are in the gate's travel range.
- ▶ If the gate system only has one safety feature, only operate the sliding gate operator if you are within sight of the gate's travel range.
- ▶ Monitor the gate travel until the gate has reached the end-of-travel position.
- ▶ Only drive or pass through remote-control gate systems when the gate is at a standstill!



## ⚠ WARNING

### Danger of crushing and shearing

Fingers or limbs may be crushed and severed if caught in the toothed track or between the gate and closing edge while the gate is in motion.

- ▶ Whenever the gate is moving, never touch the toothed track, toothed wheel, and the main or secondary closing edges.

#### 4.1 Preparation

- ▶ Before initial start-up, check that all the connecting leads are correctly installed at the connecting terminals.
- ▶ Make sure that all DIL switches are set to the factory setting (OFF) (see **Figure 7**), the gate is half open and the operator engaged.

#### Change the following DIL switches:

- ▶ **DIL switch 1:** Installation direction (see **Figure 7.1**)
  - To ON, if the gate closes towards the right.
  - To OFF, if the gate closes towards the left.
- ▶ **DIL switches 3-7:** Safety devices (see **Figures 9.6/9.7/9.8**)
  - Set according to the connected safety and protective devices (see *section 5.3 – 5.5*). These are, however, not active during set-up mode.

#### 4.2 Teaching in the gate's end-of-travel positions

##### 4.2.1 Recording the CLOSE end-of-travel position

- ▶ See **Figure 8.1a**

The limit switch (reed contact) must be connected before teaching in the end-of-travel positions. The limit switch wires must be connected at the **REED** terminal.

The option relay has the same function as the red LED during set-up. The limit switch position can be viewed from afar with a connected lamp (see **Figure 6.4**).

#### Teaching in the CLOSE end-of-travel position:

1. Open the gate halfway.
2. Set **DIL switch 2** (set-up mode) to **ON**.  
The green LED slowly flashes, the red LED remains lit.
3. Press circuit board button **T** and keep it pressed.  
The gate now travels in *CLOSE* direction at slow speed.  
The gate stops once the limit switch has been reached.
4. Immediately release circuit board button **T**.  
The red LED goes out.

The gate is now in the *CLOSE* end of travel position.

#### NOTE:

If the gate travels in the opening direction, **DIL switch 1** is in the wrong position and must be reset. Then repeat steps 1 to 4.

If the position of the gate does not correspond to the desired *CLOSE* position, a readjustment must be made.

#### Readjusting the CLOSE end-of-travel position:

1. Adjust the position of the magnet by moving the magnet slide.
2. Press circuit board button **T** until the gate reaches the readjusted end-of-travel position and the red LED goes out.
3. Repeat steps **1 + 2** until the desired end-of-travel position has been reached.

#### 4.2.2 Recording the OPEN end-of-travel position

- ▶ See **Figure 8.1b**

#### Teaching in the OPEN end-of-travel position:

4. Press circuit board button **T** and keep it pressed.  
The gate now travels in *OPEN* direction at slow speed.
5. Release circuit board button **T**, once the desired *OPEN* end-of-travel position is reached.
6. Press circuit board button **P** to confirm this position.  
The green LED flashes rapidly for 2 seconds to indicate that the *OPEN* end-of-travel position has been recorded and then goes out.

#### 4.2.3 Recording the partial opening end-of-travel position

- ▶ See **Figure 8.1c**

#### NOTE:

If press-and-hold operation has been set, it is not possible to record the *partial opening* end-of-travel position.

#### Teaching in the partial opening end-of-travel position:

1. Press circuit board button **T** and keep it pressed to move the gate back towards the *CLOSE* position.  
The green LED will flash slowly.
2. Release circuit board button **T** once the desired *partial opening* end-of-travel position is reached.
3. Press circuit board button **P** to confirm this position.  
The green LED flashes rapidly for 2 seconds to indicate that the *partial opening* end-of-travel position has been recorded and then goes out.

#### 4.2.4 Ending the set-up-mode

- ▶ After you have finished the teach-in procedure, set **DIL switch 2** back to **OFF**.  
The green LED signals that forces must be taught in by flashing quickly.

The safety equipment is active again.

#### 4.2.5 Reference run

- ▶ See **Figure 8.2**

After teaching in the end-of-travel positions, the first cycle is always a reference run. During this reference run the option relay clocks and a connected warning lamp flashes.

#### Reference run to CLOSE end-of-travel position:

- ▶ Press circuit board button **T** once.  
The operator automatically moves into the *CLOSE* end-of-travel position.
- ▶ If press-and-hold operation has been set (**DIL switch 16** to **ON**), press and hold circuit board button **T** until the gate is in the *close* end-of-travel position.

#### NOTE:

Initial start-up is now finished if press-and-hold operation has been set (**DIL switch 16** to **ON**).

#### 4.3 Learning the forces

Once the end-of-travel positions have been taught in and the reference run performed, force learning runs must also be performed. For this, three successive gate cycles must take place, during which none of the safety devices may be activated. Recording the forces takes place automatically by press-and-release operation in both directions and the option relay clocks. The green LED flashes throughout. This LED is steadily illuminated once the force learning runs have been completed (see **Figure 9.1**).

- ▶ **Both of the following procedures must be conducted three times.**

#### Force learning runs:

- ▶ Press circuit board button **T** once.  
The operator automatically moves into the *OPEN* end-of-travel position.
- ▶ Press circuit board button **T** once.  
The operator automatically moves into the *CLOSE* end-of-travel position.

#### 4.3.1 Setting the force limit

### ⚠ CAUTION

#### Danger of injury due to the force value being set too high

If the force value is set too high, the force limit is less sensitive and the gate will not stop on time when closing. This could lead to injuries and damage.

- ▶ Do not set a force value that is too high.

#### NOTE:

Due to special fitting situations, it can, however, happen that the previously taught-in forces prove inadequate, which can lead to undesired reversing. Readjust the forces in such cases.

The force limit of the gate system is set via a potentiometer that is labelled "Kraft F" on the control print (see **Figure 9.1**).

1. The increase in the force limit is a percentage increase in relation to the taught-in values where the setting of the potentiometer denotes the following force increase:

Full left	+ 0 % force
Centred	+15 % force
Full right	+75 % force

2. The taught-in force setting must be checked using a suitable force measuring device to make sure that the values are permissible within the application scope of the European Standards EN 12453 and EN 12445 or the corresponding national regulations.

#### 4.3.2 Operator speed

If the force measured with the force measuring device is still too high when the potentiometer is turned to full left, this can be changed by reducing the travel speed (see **Figure 9.2**).

#### Adjusting the speed:

1. Set **DIL switch 15** to **ON**.
2. Perform three successive force learning runs (see *section 4.3*).
3. Check again using the force measuring device.

#### 4.3.3 Switching off the force limit

#### NOTE:

#### Not for use in countries with EU directives!

The force limit can be switched off by snipping through the **BR1** wire jumper on the control print.

If no safety devices are connected (**DIL switches 3–6** to **OFF**), the operator will only work in press-and-hold operation.

If 8k2 resistance contact strips are connected (**DIL switch 3–6** to **ON**) the operator will work in-press-and-release operation without force limit.

#### Deactivating the force limit:

1. Perform a factory reset (see *section 10*).
2. Snip through the **BR1** wire jumper.
3. Set **DIL switch 2** to **ON** and teach in the operator again (see *section 4.2*).

If the wire jumper is snipped through during set-up or during gate travel, this will not have any effect on the function.

#### NOTE:

Once you have completed the teach-in procedure, the door system can only be operated using an external button.

- A permanent contact at terminals 20 + 21 moves the operator in the *Open* direction
- A permanent contact at terminals 20 + 23 moves the operator in the *Close* direction

#### Reactivating the force limit:

1. Perform a factory reset (see *section 10*).
2. Connect the **BR1** wire jumper.
3. Set **DIL switch 2** to **ON** and teach in the operator again (see *section 4.2*).

#### 4.4 Changing the starting point for slow speed when opening and closing

The slow speed length is automatically set to a basic value of approx. 500 mm before the end-of-travel positions after the end-of-travel positions have been taught in. The starting points can be reprogrammed from a minimum length of approx. 300 mm up to the entire gate length (see **Figure 9.3**).

Changing the starting points for slow speed deletes the already taught-in forces and they must be taught in again after the changes have been made.

#### Changing the starting points:

1. The end-of-travel positions must be set and the gate is in the *CLOSE* end-of-travel position and **DIL switch 2** must be set to **OFF**.
2. Set **DIL switch 12** to **ON**.
3. Press print button **T**.  
The gate will travel normally in press-and-release operation in the *OPEN* direction.
4. When the gate passes the desired position for the start of slow speed, briefly press print button **P**.  
The operator will move at slow speed for the remaining distance until in the *OPEN* end-of-travel position.
5. Press print button **T** again.  
The gate will again travel normally in press-and-release operation in the *CLOSE* direction.
6. When the gate passes the desired position for the start of slow speed, briefly press print button **P**.  
The operator will move at slow speed for the remaining distance until in the *CLOSE* end-of-travel position.
7. Set **DIL switch 12** to **OFF**.

The slow speed starting point settings have now been completed. The green LED flashes to signal that the forces must be taught in again.

#### NOTE:

The starting points for slow speed can also be set to "overlap"; in this case, the entire gate movement is in slow speed.

#### 4.5 Reversal limit

During operation of the gate in the *CLOSE* direction, the system must distinguish between two possibilities: whether the gate contacts the end stop (gate system stops) or an obstruction (gate reverses direction). The limit range can be adjusted as follows (see **Figure 9.4**).

##### Setting the reversal limit:

1. Set **DIL switch 11** to **ON**.  
The reversal limit can now be set step-by-step.
2. Briefly press print button **P** to **decrease** the reversal limit. Briefly press print button **T** to **increase** the reversal limit. During adjustment, the green LED will indicate the following settings:

<b>1x flashing up to</b>	Minimum reversal limit, the green LED flashes once
<b>10x flashing</b>	Maximum reversal limit, the green LED flashes 10 times

3. Set **DIL switch 11** back to **OFF** to store the set reversal limit.

#### 4.6 Automatic timed closing

##### NOTE:

Automatic timed closing can only be activated if at least one safety device has been connected. This is required according to DIN EN 13241-1.

The hold-open phase can be set for operation with automatic timed closing (see **Figure 9.5**).

##### Setting the hold-open phase:

1. Set **DIL switch 13** to **ON**.  
The hold-open phase can now be set in increments.
2. Briefly press print button **P** to **decrease** the hold-open phase.  
Briefly press print button **P** to **increase** the hold-open phase.  
During adjustment, the green LED will indicate the following settings:

<b>1x flashing</b>	30 second hold-open phase
<b>2x flashing</b>	60 second hold-open phase
<b>3x flashing</b>	90 second hold-open phase
<b>4x flashing</b>	120 second hold-open phase
<b>5x flashing</b>	180 second hold-open phase

3. Set **DIL switch 13** back to **OFF** to store the set hold-open phase.

### **WARNING**

#### **Danger of injuries due to faulty safety equipment**

In the event of a malfunction, there is a danger of injuries due to faulty safety equipment.

- ▶ After the learning runs, the person commissioning the system must check the function(s) of the safety equipment.

**The system is ready for operation only after this.**

## 5 DIL Switch Functions

The control is programmed via the DIL switches. Before initial start-up, the DIL switches are in the factory settings, i.e. all the switches are in the OFF position. Changes to the DIL switch settings are only permissible under the following conditions:

- The operator is at rest.
- The warning or hold-open phase is not active.

The DIL switches must be set as described below in accordance with the national regulations, the desired safety equipment and the on-site circumstances.

### 5.1 DIL switch 1

#### Installation direction:

- ▶ See **Figure 7.1**

<b>1 ON</b>	Gate closes to the right (as viewed from the operator)
<b>1 OFF</b> 	Gate closes to the left (as viewed from the operator)

### 5.2 DIL switch 2

#### Set-up mode:

- ▶ See **Figures 8.1a–c**

The safety and protective devices are not active during set-up mode.



<b>2 ON</b>	<ul style="list-style-type: none"> <li>• Teach-in gate travel</li> <li>• Delete gate data</li> </ul>
<b>2 OFF</b> 	Normal mode

### 5.3 DIL switch 3/DIL switch 4

#### SE1 safety device (opening):

- ▶ See **Figure 9.6**

The functions of the SE1 are set with **DIL switch 3** in combination with **DIL switch 4**.

<b>3 ON</b>	Activation kit for closing edge safety device or photocell with testing
<b>3 OFF</b> 	<ul style="list-style-type: none"> <li>• 8k2 resistance contact strip</li> <li>• Photocell from another manufacturer</li> <li>• No safety device (8k2 resistance between terminals 20/72, delivery status)</li> </ul>
<b>4 ON</b>	Brief, immediate reversing in the <i>CLOSE</i> direction (for SKS)
<b>4 OFF</b> 	Brief, delayed reversing in the <i>CLOSE</i> direction (for photocell)



## ENGLISH

## 5.4 DIL switch 5/DIL switch 6

## SE2 safety device (closing):

► See Figure 9.7

The functions of the SE2 are set with **DIL switch 5** in combination with **DIL switch 6**.

<b>5 ON</b>	Activation kit for closing edge safety device or photocell with testing
<b>5 OFF</b> 	<ul style="list-style-type: none"> <li>8k2 resistance contact strip</li> <li>Photocell from another manufacturer</li> <li>No safety device (8k2 resistance between terminals 20/73, delivery status)</li> </ul>
<b>6 ON</b>	Brief, immediate reversing in the OPEN direction (for SKS)
<b>6 OFF</b> 	Brief, delayed reversing in the OPEN direction (for photocell)

## 5.5 DIL switch 7

## SE3 protective device (closing):

► See Figure 9.8

Delayed reversing to *OPEN* end-of-travel position.

<b>7 ON</b>	Dynamic 2-wire photocell
<b>7 OFF</b> 	<ul style="list-style-type: none"> <li>Static photocell without testing</li> <li>No safety device (wire jumper between terminals 20/71, delivery status)</li> </ul>

## 5.6 DIL switch 8/DIL switch 9

The functions of the operator (automatic timed closing/pre-warning phase) and the function of the option relay are set with **DIL switch 8** in combination with **DIL switch 9**.

► See Figure 9.9a

<b>8 ON</b>	<b>9 ON</b>	<b>Operator</b> Automatic timed closing, pre-warning phase for each gate movement
		<b>Option relay</b> Relay clocks rapidly during the pre-warning phase, normally during the travel phase and is OFF during the hold-open phase.



► See Figure 9.9b

<b>8 OFF</b> 	<b>9 ON</b>	<b>Operator</b> Automatic timed closing, pre-warning time only for automatic timed closing
		<b>Option relay</b> Relay clocks rapidly during the pre-warning phase, normally during the travel phase and is OFF during the hold-open phase.

► See Figure 9.9c

<b>8 ON</b>	<b>9 OFF</b> 	<b>Operator</b> Pre-warning phase for each gate movement without automatic timed closing
		<b>Option relay</b> Relay clocks rapidly during the pre-warning phase, normally during the travel phase.

► See Figure 9.9d

<b>8 OFF</b> 	<b>9 OFF</b> 	<b>Operator</b> No special function
		<b>Option relay</b> Relay picks up in the <i>CLOSE</i> end-of-travel position.

## NOTE:

Automatic timed closing is only possible from the determined end-of-travel positions (full or partial opening). Automatic timed closing is deactivated if it fails three times. The operator must be restarted with an impulse.

## 5.7 DIL switch 10

## Effect of the SE3 protective device as a through-traffic photocell with automatic timed closing

► See Figure 9.10

<b>10 ON</b>	The photocell is activated as a through-traffic photocell, after the photocell has been passed, the hold-open phase is reduced.
<b>10 OFF</b> 	The photocell is not activated as a through-traffic photocell. If, however, <i>automatic timed closing</i> is activated and the photocell interrupted after the hold-open phase has elapsed, the hold-open phase will be reset to the preset time.

## 5.8 DIL switch 11

## Setting the reversal limits:

► See Figure 9.4 and section 4.5

<b>11 ON</b>	Reversal limit set step-by-step
<b>11 OFF</b> 	Normal mode

## 5.9 DIL switch 12

## Starting point for slow speed when opening and closing:

► See Figure 9.3 and section 4.4

<b>12 ON</b>	Starting points are set for slow speed when opening and closing
<b>12 OFF</b> 	Normal mode

## 5.10 DIL switch 13

## Setting the hold-open phase:

► See Figure 9.5 and section 4.6

<b>13 ON</b>	Hold-open phase is set in increments
<b>13 OFF</b> 	Normal mode

### 5.11 DIL switch 14

#### Impulse behaviour during the hold-open phase:

The impulse behaviour during the hold-open phase can be set for operation with automatic timed closing.

<b>14 ON</b>	An impulse cancels the hold-open phase. The operator closes the gate after the pre-warning phase has elapsed.
<b>14 OFF</b> 	An impulse increases the hold-open phase by the pre-set time.

### 5.12 DIL switch 15

#### Setting the speed:

► See **Figure 9.2** and *section 4.3.2*

<b>15 ON</b>	Slow mode (slow speed); (no SKS required)
<b>15 OFF</b> 	Normal mode (normal speed)

### 5.13 DIL switch 16

#### Setting the operating mode:

Press-and-hold operation can be set with **DIL switch 16**. The force limit is set to the maximum value.

<b>16 ON</b>	Press-and-hold operation <ul style="list-style-type: none"> <li>• A permanent contact at terminals 20 + 21 moves the operator in the <i>OPEN</i> direction</li> <li>• A permanent contact at terminals 20 + 23 moves the operator in the <i>CLOSE</i> direction</li> <li>• The operator stops if the respective contact is interrupted</li> </ul>
<b>16 OFF</b> 	Normal mode

#### NOTE:

Special functions are possible during press-and-hold operation in conjunction with a universal adapter print UAP 1.

## 6 Radio

#### NOTE:



Depending on the type of operator, the scope of delivery for the sliding door operator includes an external receiver or an external receiver has to be ordered separately to operate a remote-controlled system.

 <b>CAUTION</b>
<b>Danger of injuries due to unintended door travel</b> Unintended door travel may occur while teaching in the radio system. ► Make sure no persons or objects are in the door's area of travel when teaching in the radio system.

- After programming or extending the radio system, perform a function test.
- Only use original components when putting the radio system into service or extending it.
- Local conditions may affect the range of the radio system.

- When used at the same time, GSM 900 mobile phones can affect the range.

### 6.1 Hand transmitter HS 4 BiSecur

 <b>WARNING</b>
 <p><b>Danger of injury during door travel</b> Persons may be injured by door travel if the hand transmitter is actuated.</p> <ul style="list-style-type: none"> <li>► Make sure that the hand transmitters are kept away from children and can only be used by people who have been instructed on how the remote-control door functions!</li> <li>► If the door has only one safety device, only operate the hand transmitter if you are within sight of the door!</li> <li>► Only drive or pass through remote-control door systems when the door is at a standstill!</li> <li>► Never stand in the opening of the door system.</li> <li>► Please note that unwanted door travel may occur if a hand transmitter button is accidentally pressed (e.g. if stored in a pocket / handbag).</li> </ul>

### ATTENTION

#### Functional impairment due to environmental influences

Non-compliance with these instructions can impair function!

Protect the hand transmitter from the following conditions:

- Direct sunlight (permissible ambient temperature: -20 °C to +60 °C)
- Moisture
- Dust

#### 6.1.1 Description of the hand transmitter

- See **Figure 10**
- 1 LED, multicolour
- 2 Hand transmitter buttons
- 3 Battery lid
- 4 Battery

#### 6.1.2 Inserting / changing the battery

► See **Figure 10**

After inserting the battery, the hand transmitter is ready for operation.

### ATTENTION

#### Destruction of the hand transmitter by leaking batteries

Batteries can leak and destroy the hand transmitter.

- Remove the battery from the hand transmitter if it is out of use for a long period of time.

## ENGLISH

**6.1.3 Hand transmitter operation**

Each hand transmitter button is assigned to a radio code. Press the button of the hand transmitter whose radio code you want to transmit.

- The radio code is transmitted and the LED is illuminated blue for 2 seconds.

**NOTE:**

If the battery is almost empty, the LED flashes red twice

- before transmitting the radio code.
  - ▶ The battery **should be** replaced soon.
- and the radio code is not transmitted.
  - ▶ The battery **must be** replaced immediately.

**6.1.4 Inheriting / transmitting a radio code**

- Press the button of the hand transmitter whose radio code you want to inherit / transmit and keep it pressed.
  - The radio code is transmitted and the LED is illuminated blue for 2 seconds and then goes out.
  - After 5 seconds, the LED alternates flashing in red and blue; the radio code is transmitted.
- If the radio code is transmitted and recognised, release the hand transmitter button.
  - The LED goes out.

**NOTE:**

You have 15 seconds to inherit / transmit the code. The process must be repeated if the radio code is not successfully inherited / transmitted within this time.

**6.1.5 Hand transmitter reset**

Each hand transmitter button is assigned to a new radio code by means of the following steps.

- Open the battery lid and remove the battery for 10 seconds.
- Press a circuit board button and keep it pressed.
- Insert the battery.
  - The LED slowly flashes in blue for 4 seconds.
  - The LED flashes rapidly in blue for 2 seconds.
  - The LED is illuminated blue for a long time.
- Release the circuit board button.
 

**All radio codes are newly assigned.**
- Close the hand transmitter housing.

**NOTE:**

If the circuit board button is released prematurely, no new radio codes are assigned.

**6.1.6 LED display****Blue (BU)**

Condition	Operation
Illuminated for 2 seconds	A radio code is being transmitted
Flashes slowly	Hand transmitter is in the learn mode
Flashes quickly after slow flashing	A valid radio code was detected during the learning run
Flashes slowly for 4 seconds Flashes quickly for 2 seconds Illuminated long	Device reset is being performed or completed

**Red (RD)**

Condition	Operation
Flashes 2 ×	The battery is almost empty

**Blue (BU) and Red (RD)**

Condition	Operation
Flashing alternately	Hand transmitter is in inherit / transmit mode

**6.1.7 Cleaning the hand transmitter****ATTENTION****Damaging the hand transmitter by faulty cleaning**

Cleaning the hand transmitter with unsuitable cleaning agents can damage the hand transmitter housing as well as the hand transmitter buttons.

- ▶ Clean the hand transmitter with a clean, soft, damp cloth.

**NOTE:**

White hand transmitter buttons can change their colour when used regularly over an extended period of time, if they come in contact with cosmetic products (e.g. hand cream).

**6.1.8 Disposal****Hand transmitters**

Electrical and electronic devices, as well as batteries, may not be disposed of in household rubbish. They must be returned to the appropriate recycling facilities.

**6.1.9 Technical data**

Type	Hand transmitter HS 4 BiSecur
Frequency	868 MHz
Power supply	1 × 1.5 V battery, type: AAA (LR03)
Perm. ambient temperature	–20 °C to +60 °C
Protection category	IP 20

**6.1.10 Excerpt from the declaration of conformity for the hand transmitter**

Conformity of the abovementioned product with the requirements of the directives according to article 3 of the R & TTE directives 1999/5/EC was verified by compliance with the following standards:

- EN 60950:2000
- EN 300 220-1
- EN 300 220-3
- EN 301 489-1
- EN 300 489-3

The original declaration of conformity can be requested from the manufacturer.

## 6.2 Radio receiver

### 6.2.1 External receiver\*

A maximum number of 100 radio codes per channel can be taught in the receiver. If the same radio code is taught in on two different channels, it will be deleted on the first taught-in channel.

Radio teaching / deleting data is only possible if the following applies:

- No set-up mode is activated (**DIL switch 2 to OFF**)
- The operator is at rest.
- The pre-warning or hold-open phase is not active.

### 6.2.2 Teaching in hand transmitter buttons

Teach in the hand transmitter button for the functions *Impulse* (channel 1) or *Partial opening* (channel 2) using the operating instructions for the external receiver.

1. Press the **P** button to activate the desired channel.
  - The LED will flash slowly in blue for channel 1.
  - The LED will flash blue twice for channel 2.
  - The LED will flash blue three times for channel 3 (without function)
2. Put the hand transmitter whose radio code is to be inherited into the **Inheriting / Transmitting** mode. If a valid radio code is detected, the LED flashes quickly in blue and then goes out.

### 6.2.3 Deleting all radio codes

- ▶ Delete the radio codes of all the hand transmitter buttons by following the operating instructions for the external receiver.

### 6.2.4 Excerpt from the declaration of conformity for the receiver

Conformity of the abovementioned product with the requirements of the directives according to article 3 of the R & TTE directives 1999/5/EC was verified by compliance with the following standards:

- EN 300 220-3
- EN 301 489-1
- EN 300 489-3

The original declaration of conformity can be requested from the manufacturer.

## 7 Final Work

- ▶ Replace the transparent cover (see **Figure 12**) and close the housing cover after completing all of the steps required for initial start-up.

### 7.1 Fixing the warning sign

- ▶ See **Figure 13**
- ▶ Fix the sign warning about getting trapped in a noticeable, cleaned and degreased place, for example, near to the permanently installed button for moving the operator.

## 8 Operation

	<p style="text-align: center;"><b>⚠ WARNING</b></p> <p><b>Danger of injury during gate travel</b> If people or objects are in the area around the gate while the gate is in motion, this can lead to injuries or damage.</p> <ul style="list-style-type: none"> <li>▶ Make sure that children are not playing near the gate system.</li> <li>▶ Make sure that no persons or objects are in the gate's travel range.</li> <li>▶ If the gate system only has one safety feature, only operate the sliding gate operator if you are within sight of the gate's travel range.</li> <li>▶ Monitor the gate travel until the gate has reached the end-of-travel position.</li> <li>▶ Only drive or pass through remote-control gate systems when the gate is at a standstill!</li> </ul>
---	--

<p style="text-align: center;"><b>⚠ WARNING</b></p> <p><b>Danger of crushing and shearing</b> Fingers or limbs may be crushed and severed if caught in the toothed track or between the gate and closing edge while the gate is in motion.</p> <ul style="list-style-type: none"> <li>▶ Whenever the gate is moving, never touch the toothed track, toothed wheel, and the main or secondary closing edges.</li> </ul>
--

### 8.1 Instructing users

- ▶ All persons using the gate system must be shown how to operate it properly and safely.
- ▶ Demonstrate and test the mechanical release as well as the safety return.

### 8.2 Function check

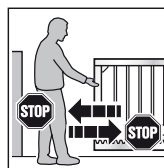

1. To check the safety reversal, stop the gate with both hands while it is closing. The gate system must stop and initiate the safety reversal.
  2. Proceed in the same manner while the gate is opening. The gate system must stop and reverse briefly.
- ▶ In the event of a failure of the safety reversal, a specialist must be commissioned immediately for the inspection and repair work.

\* Depending on the operator type, possible accessory:  
Accessory, not included as standard equipment!



### 8.3 Normal operation

#### NOTE:

If the radio code for the taught-in hand transmitter was copied from another hand transmitter, the hand transmitter button must be pressed a second time during **initial** start-up.

During normal mode, the sliding gate operator only works according to the impulse sequence control (OPEN-STOP-CLOSE-STOP). It does not matter whether an external button, hand transmitter button or circuit board button **T** has been actuated:

- ▶ To open and close fully, press the appropriate impulse generator for channel 1.
- ▶ To open and close partially, press the appropriate impulse generator for channel 2.

### 8.4 Behaviour during a power failure

To be able to open or close the sliding gate by hand during a power failure, it must be disengaged from the operator.

#### ATTENTION!

##### Damage due to moisture

- ▶ Protect the control from moisture when you open the operator housing.
1. Open the housing cover as shown in **Figure 3.1**.
  2. Release the operator by turning the locking mechanism. If necessary, press the motor and toothed wheel down by hand (see **Figure 14.1**).

### 8.5 Behaviour following a power failure

Once the power supply has been restored, the gate must be reengaged with the operator upstream from the limit switch.

- ▶ Slightly lift the motor while locking it (see **Figure 14.2**).

## 9 Inspection and Maintenance

The sliding gate operator is maintenance-free.

In the interest of your own safety, we recommend having the gate system inspected and maintained by a qualified person in accordance with the manufacturer's specifications.



### WARNING

#### Danger of injury due to unexpected gate travel

Unexpected gate travel can result during inspection and maintenance work if the gate system is inadvertently actuated by other persons.

- ▶ Disconnect the mains plug **and**, if applicable, the plug of the emergency battery when performing all work on the gate system.
- ▶ Safeguard the gate system against being switched on again without authorisation.

Inspection and repairs may only be carried out by a qualified person. Contact your supplier for this purpose.

A visual inspection may be carried out by the operator.

- ▶ Check all safety and protective functions **monthly**.
- ▶ Check the function of the resistance contact strips 8k2 **every six months**.
- ▶ Malfunctions and/or defects at hand must be rectified **immediately**.

## 10 Displays for Operating Conditions, Errors and Warnings

- ▶ See LED GN and LED RT in **Figure 6**

### 10.1 LED GN

The green LED indicates the operating condition of the control:

<p><b>Steady illumination</b> Normal state, all end-of-travel positions and forces taught-in.</p>
<p><b>Fast flashing</b> Force learning runs must be performed.</p>
<p><b>Slow flashing</b> Set-up mode – end-of-travel position setting</p>
<p><b>When setting the reversal limits</b> Flashing frequency is proportional to the selected reversal limit</p> <ul style="list-style-type: none"> <li>• Minimum reversal limit: The green LED flashes 1x</li> <li>• Maximum reversal limit: The green LED flashes 10x</li> </ul>
<p><b>When setting the hold-open phase</b> Flashing frequency depends on the set time</p> <ul style="list-style-type: none"> <li>• Minimum hold-open phase: LED flashes 1x</li> <li>• Maximum hold-open phase: LED flashes 5x</li> </ul>

### 10.2 LED RT

The red LED indicates:

<p><b>In set-up mode</b></p> <ul style="list-style-type: none"> <li>• Limit switch actuated = LED is off</li> <li>• Limit switch not actuated = LED is on</li> </ul>
<p><b>Display of the button inputs, radio</b></p> <ul style="list-style-type: none"> <li>• Actuated = LED is on</li> <li>• Not actuated = LED is off</li> </ul>
<p><b>In normal mode</b> Flashing code as an error/diagnosis display</p>

### 10.3 Display of error and warning messages

The red LED RT helps to easily identify causes when operation does not go according to plan.

#### NOTE:

If normal operation of the sliding gate operator with the radio receiver or circuit board button **T** is otherwise possible, a short circuit in the external button's connecting lead or in the button itself can be recognised through the behaviour described here.



<p><b>Display flashes 2x</b></p> <p><b>Error/warning</b> Safety/protective device has responded</p> <p><b>Possible cause</b></p> <ul style="list-style-type: none"> <li>• Safety/protective device has been actuated</li> <li>• Safety/protective device defective</li> <li>• Without SE1, 8k2 resistance between terminals 20 and 72 missing</li> <li>• Without SE2, 8k2 resistance between terminals 20 and 73 missing</li> <li>• Without SE3, wire jumper between terminals 20 and 71 missing</li> </ul> <p><b>Remedy</b></p> <ul style="list-style-type: none"> <li>• Check safety/protective device</li> <li>• Check whether the appropriate resistance/wire jumpers are present without the connected safety/protective device</li> </ul>
<p><b>Display flashes 3x</b></p> <p><b>Error/warning</b> Force limit in CLOSE direction</p> <p><b>Possible cause</b> Obstruction in gate area</p> <p><b>Remedy</b> Remove the obstruction; check forces, increase if necessary</p>
<p><b>Display flashes 4x</b></p> <p><b>Error/warning</b> Hold or static current circuit is open, operator at a standstill</p> <p><b>Possible cause</b></p> <ul style="list-style-type: none"> <li>• Normally closed contact at terminal 12/13 is open</li> <li>• Electric circuit interrupted</li> </ul> <p><b>Remedy</b></p> <ul style="list-style-type: none"> <li>• Close contact</li> <li>• Check electric circuit</li> </ul>
<p><b>Display flashes 5x</b></p> <p><b>Error/warning</b> Force limit in OPEN direction</p> <p><b>Possible cause</b> Obstruction in gate area</p> <p><b>Remedy</b> Remove the obstruction; check forces, increase if necessary</p>
<p><b>Display flashes 6x</b></p> <p><b>Error/warning</b> System error</p> <p><b>Possible cause</b> Internal error</p> <p><b>Remedy</b> Perform a factory reset (see section 10) and teach in the control again (see section 4.2), or exchange it if necessary</p>
<p><b>Display flashes 7x</b></p> <p><b>Error/warning</b> Peak force</p> <p><b>Possible cause</b></p> <ul style="list-style-type: none"> <li>• Motor blocked</li> <li>• Force cut-out has not responded</li> </ul> <p><b>Remedy</b> Check the motor for seizure</p>

#### 10.4 Error acknowledgement

If an error occurs, this can be acknowledged, provided the error is no longer present.

- ▶ Actuate an internal or external impulse generator. The error is deleted and the gate travels in the corresponding direction.

### 11 Resetting the Control/Restoring Factory Settings

**To reset the control (taught-in end-of-travel positions, forces):**

1. Set **DIL switch 2** to **ON**.
2. Immediately press circuit board button **P** briefly.
3. When the red LED flashes rapidly, **DIL switch 2** must be quickly set to **OFF**.

The control system has now been reset to the factory setting.

### 12 Dismantling and Disposal

#### NOTE:

When disassembling, observe the applicable regulations regarding occupational safety.

Have a specialist dismantle the sliding gate operator in the reverse order of these fitting instructions and dispose of it properly.

### 13 Optional Accessories

Optional accessories are not included in the scope of delivery. Loading of the operator by all electrical accessories: max. 500 mA.

The following accessories, among others, are available:

- External radio receivers
- External impulse buttons (e.g. key switch)
- External code and transponder switches
- One-way photocell
- Warning lamps/warning lights
- Photocell expanders
- Universal adapter print UAP 1
- HNA outdoor emergency battery
- Further accessories available on request

## 14 Warranty Conditions

### Warranty

We shall be exempt from our warranty obligations and product liability in the event that the customer carries out his own structural alterations or undertakes improper installation work or arranges for same to be carried out by others without our prior approval and contrary to the fitting guidelines we have provided. Furthermore, the manufacturer assumes no responsibility for the accidental or careless operation of the operator and accessories, as well as for improper maintenance of the gate or for a non-authorised method of fitting the gate. Batteries are also not covered by the warranty.

### Warranty period

In addition to the statutory warranty provided by the dealer in the sales contract, we grant the following warranty for parts from the date of purchase:

- 5 years for the operator mechanics, motor and motor control
- 2 years on radio equipment, impulse generator, accessories and special systems

There is no warranty on consumables (e.g. fuses, batteries, lamps). Claims made under the warranty do not extend the warranty period. For replacement parts and repairs the warranty period is six months or at least the remainder of the warranty period.

### Prerequisites

A claim under this warranty is only valid for the country in which the equipment was bought. The product must have been purchased through our authorised distribution channels. A claim under this warranty exists only for damage to the object of the contract itself. Reimbursement of expenditure for dismantling and fitting, testing of corresponding parts, as well as demands for lost profits and compensation for damages, are excluded from the warranty.

The receipt of purchase substantiates your right to claim under the warranty.

### Performance

For the duration of the warranty we shall eliminate any product defects that are proven to be attributable to a material or manufacturing fault. We pledge to replace free of charge and at our discretion the defective goods with non-defective goods, to carry out repairs, or to grant a price reduction.

Damages caused by the following are excluded:

- improper fitting and connection
- improper initial start-up and operation
- external factors such as fire, water, abnormal environmental conditions
- mechanical damage caused by accidents, falls, impacts
- negligent or intentional destruction
- normal wear or deficient maintenance
- repairs conducted by unqualified persons
- use of non-original parts
- removal or defacing of the data label

Replaced parts become our property.

## 15 Excerpt from the Declaration of Incorporation

(as defined in EC Machinery Directive 2006/42/EC for incorporation of partly completed machinery according to annex II, part B)

The product described on the reverse side has been developed, constructed and produced in accordance with the following directives:

- EC Machinery Directive 2006/42 EC
- EC Construction Products Directive 89/106/EEC
- EC Low-Voltage Directive 2006/95/EC
- EC Electromagnetic Compatibility Directive 2004/108/EC

Applied and consulted standards and specifications:

- EN ISO 13849-1, PL "c", Cat. 2  
Safety of machinery – Safety-related parts of control systems – Part 1: General principles
- EN 60335-1/2, when applicable  
Safety of electrical appliances / Operators for doors
- EN 61000-6-3  
Electromagnetic compatibility – Electromagnetic radiation
- EN 61000-6-2  
Electromagnetic compatibility – Interference immunity

Partly completed machinery as defined in the EC Directive 2006/42/EC is only intended to be incorporated into or assembled with other machinery or other partly completed machinery or equipment, thereby forming machinery to which this directive applies.











This is why this product must only be put into operation after it has been determined that the entire machine/system in which it will be installed corresponds with the guidelines of the EC Directive mentioned above.





Any modification made to this product without our express permission and approval shall render this declaration null and void.

## 16 Technical Data

<b>Max. gate width</b>	Depending on operator type: 6,000 mm/8,000 mm/ 10,000 mm
<b>Max. gate height</b>	Depending on operator type: 2,000 mm/3,000 mm
<b>Max. gate weight</b>	Depending on operator type: Floor-guided 300 kg/500 kg/800 kg Self-supporting 250 kg/400 kg/600 kg
<b>Rated load</b>	See data label
<b>Max. pull and push force</b>	See data label
<b>Operator housing</b>	Diecast zinc and weather-resistant plastic
<b>Mains voltage</b>	Rated voltage 230 V/50 Hz
<b>Control</b>	Microprocessor control system, programmable via 16 DIL switches, control voltage 24 V DC
<b>Operating mode</b>	S2, short-time duty 4 minutes
<b>Temperature range</b>	-20°C to +60°C
<b>Travel/force limit</b>	Electronic
<b>Automatic safety cut-out</b>	Force limit for both operational directions, self-programming and testing
<b>Hold-open phase</b>	<ul style="list-style-type: none"> <li>• Adjustable between 30 - 180 seconds (photozell required)</li> <li>• 5 seconds (shorter hold-open phase with through-traffic photozell)</li> </ul>
<b>Motor</b>	24 V DC motor and worm gear
<b>Protection category</b>	IP 44
<b>Radio components</b>	Depending on operator type: <ul style="list-style-type: none"> <li>• 3-channel receiver</li> <li>• Hand transmitter</li> <li>• Without radio</li> </ul>

## 17 Overview of DIL Switch Functions

<b>DIL 1</b>	<b>Installation direction</b>			
ON	Gate closes to the right (as viewed from the operator)			
OFF	Gate closes to the left (as viewed from the operator)			
<b>DIL 2</b>	<b>Set-up mode</b>			
ON	Set-up mode (limit switch and OPEN end-of-travel position)/delete gate data (reset)			
OFF	Normal mode in press-and-release operation			
<b>DIL 3</b>	<b>Type of SE1 safety device (connection at terminal 72) when opening</b>			
ON	Safety device with testing (SKS activating kit or photocell)			
OFF	8k2 resistance contact strip, photocell from another manufacturer or none (8k2 resistance between terminal 72 and 20)			
<b>DIL 4</b>	<b>Effect of SE1 safety device (connection at terminal 72) when opening</b>			
ON	SE1 activation triggers brief, immediate reversing (for SKS)			
OFF	SE1 activation triggers brief, delayed reversing (for photocell)			
<b>DIL 5</b>	<b>Type of SE2 safety device (connection at terminal 73) when closing</b>			
ON	Safety device with testing (SKS activating kit or photocell)			
OFF	8k2 resistance contact strip, photocell from another manufacturer or none (8k2 resistance between terminal 73 and 20)			
<b>DIL 6</b>	<b>Effect of SE2 safety device (connection at terminal 73) when closing</b>			
ON	SE2 activation triggers brief, immediate reversing (for SKS)			
OFF	SE2 activation triggers brief, delayed reversing (for photocell)			
<b>DIL 7</b>	<b>Type and effect of SE3 protective device (connection tml. 71) when closing</b>			
ON	SE3 protective device is a dynamic 2-wire photocell			
OFF	SE3 protective device is a non-tested, static photocell			
<b>DIL 8</b>	<b>DIL 9</b>	<b>Operator function (automatic timed closing)</b>	<b>Option relay function</b>	
ON	ON	Automatic timed closing, pre-warning time for each gate movement	Clocks rapidly during pre-warning phase, normally during travel phase, is OFF during hold-open phase	
OFF	ON	Automatic timed closing, pre-warning time only for automatic timed closing	Clocks rapidly during pre-warning phase, normally during travel phase, is OFF during hold-open phase	
ON	OFF	Pre-warning phase for each gate movement without automatic timed closing	Clocks rapidly during pre-warning phase, normally during travel phase	
OFF	OFF	No special function	Picks up in the <i>CLOSE</i> end-of-travel position	
<b>DIL 10</b>	<b>Through-traffic photocell with automatic timed closing</b>			
ON	SE3 protective device activated as through-traffic photocell			
OFF	SE3 protective device not activated as through-traffic photocell			
<b>DIL 11</b>	<b>Set reversal limit</b>			
ON	Reversal limit set step-by-step			
OFF	Normal mode			
<b>DIL 12</b>	<b>Setting the slow speed starting point for opening and closing</b>			
ON	Starting points for slow speed when opening and closing			
OFF	Normal mode			

<b>DIL 13</b>	<b>Set hold-open phase</b>		
ON	Hold-open phase is set in increments		
OFF	Normal mode		
<b>DIL 14</b>	<b>Impulse behaviour during the hold-open phase</b>		
ON	Impulse cancels the hold-open phase		
OFF	Impulse extends the hold-open phase by the pre-set value		
<b>DIL 15</b>	<b>Setting the speed</b>		
ON	Slow mode (slow speed) (no SKS required)		
OFF	Normal mode (normal speed)		
<b>DIL 16</b>	<b>Setting the operating mode</b>		
ON	Press-and-hold operation		
OFF	Normal mode		

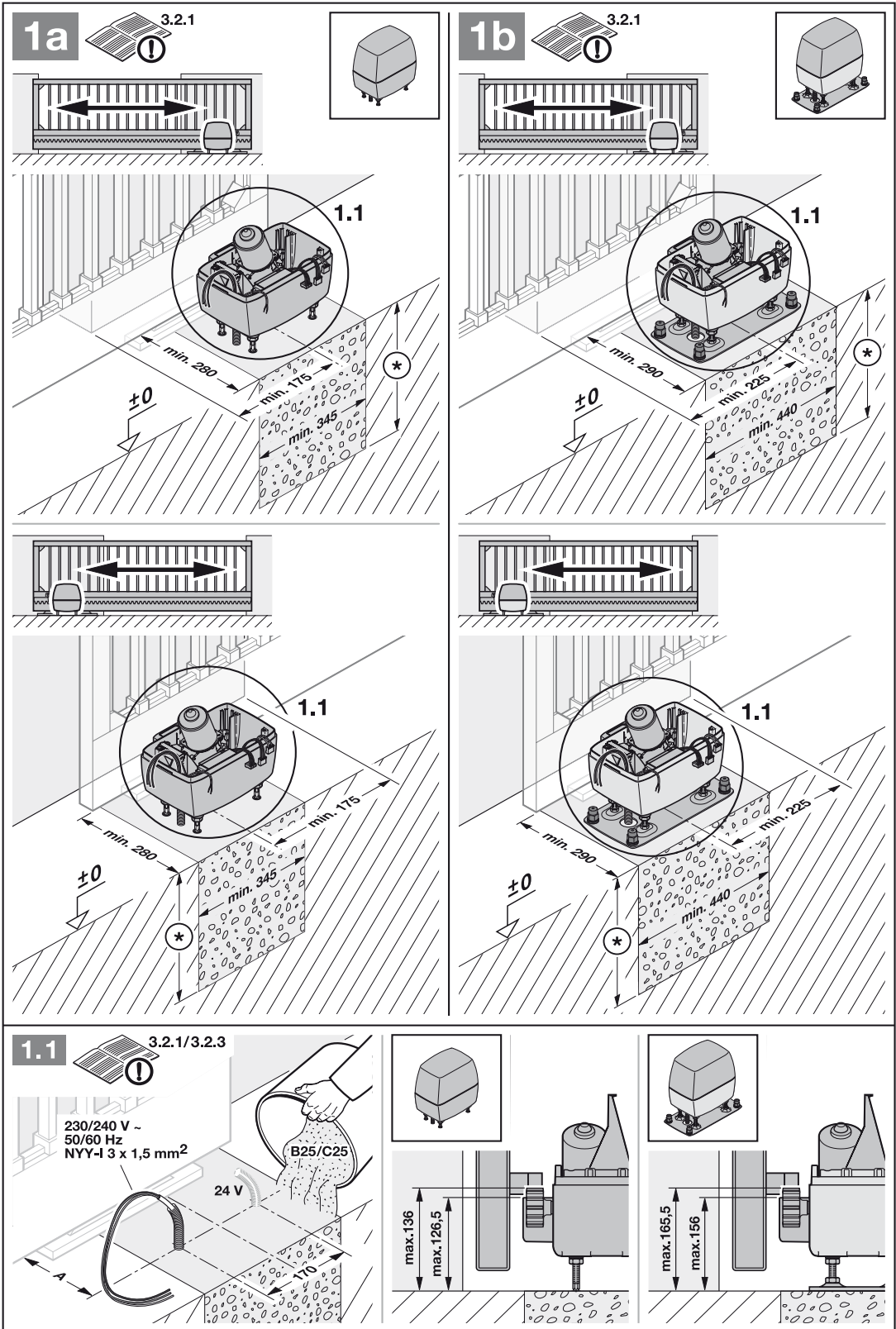

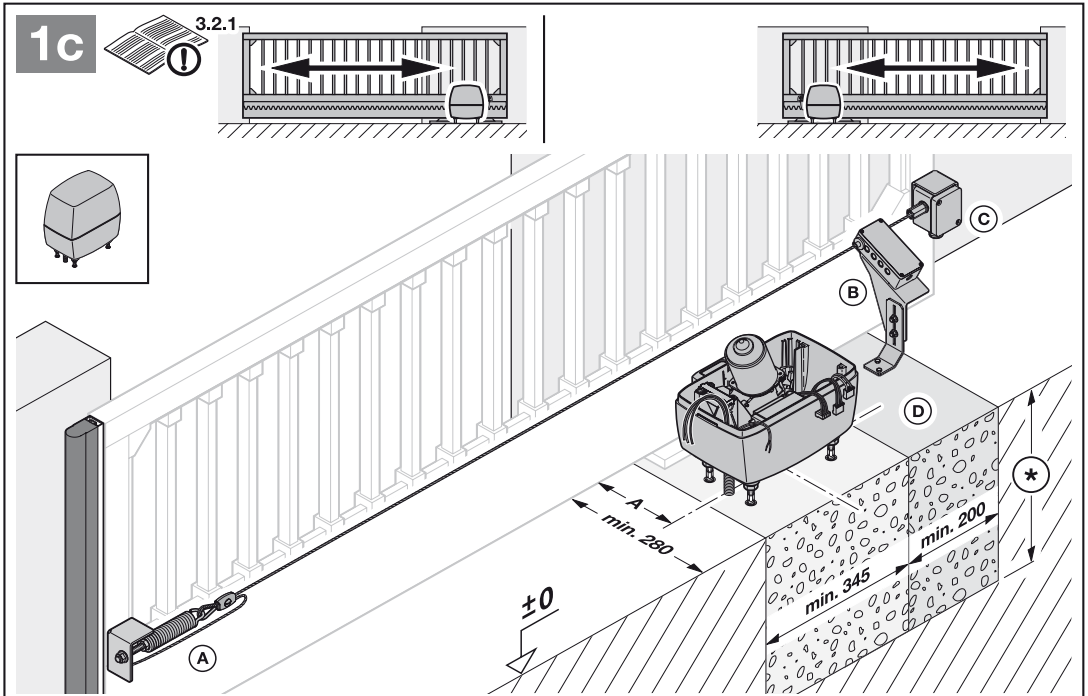

**1c.1**

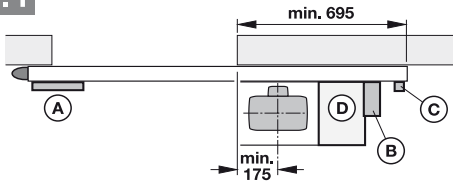

**1c.5**

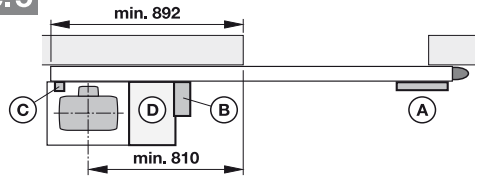

**1c.2**

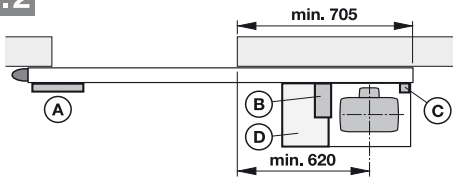

**1c.6**

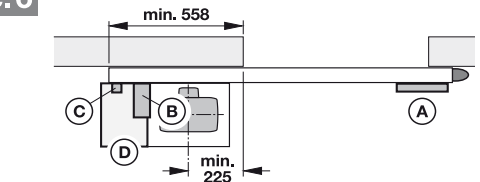

**1c.3**

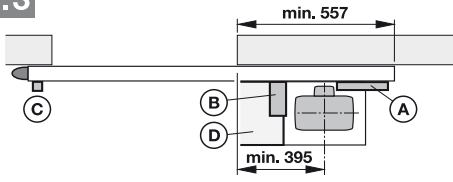

**1c.7**

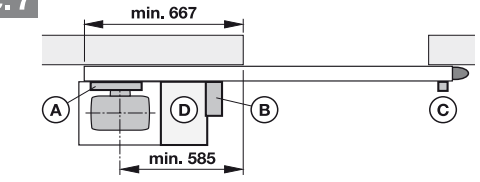

**1c.4**

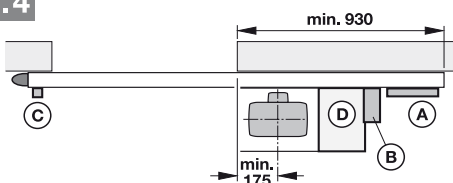

**1c.8**

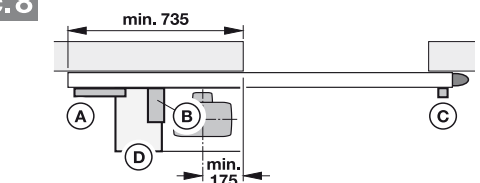

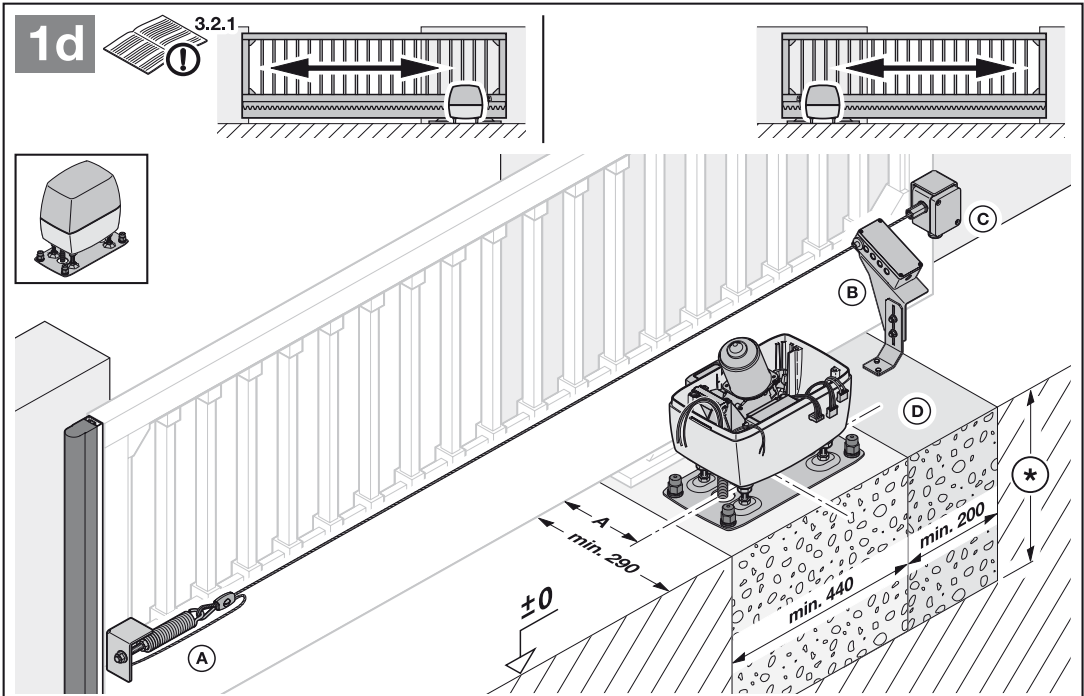

**1d.1**

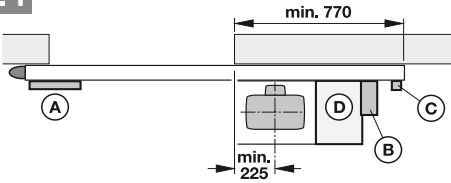

**1d.5**

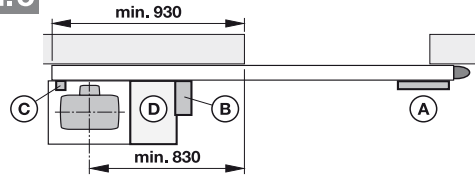

**1d.2**

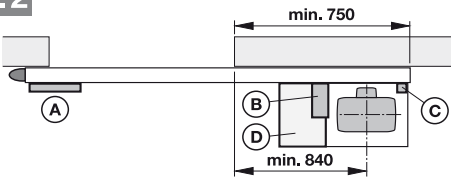

**1d.6**

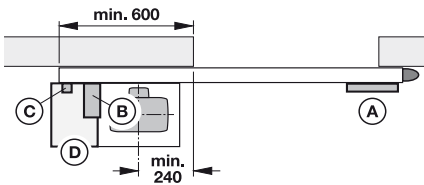

**1d.3**

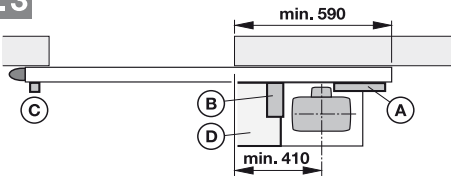

**1d.7**

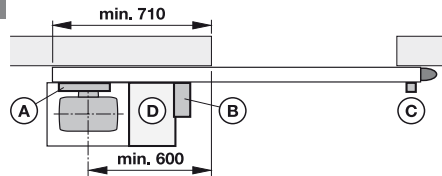

**1d.4**

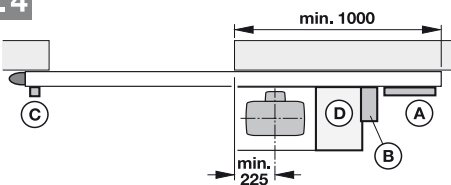

**1d.8**

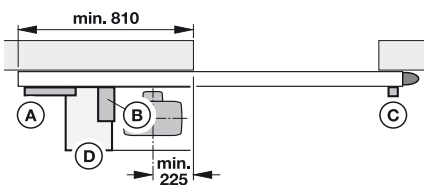



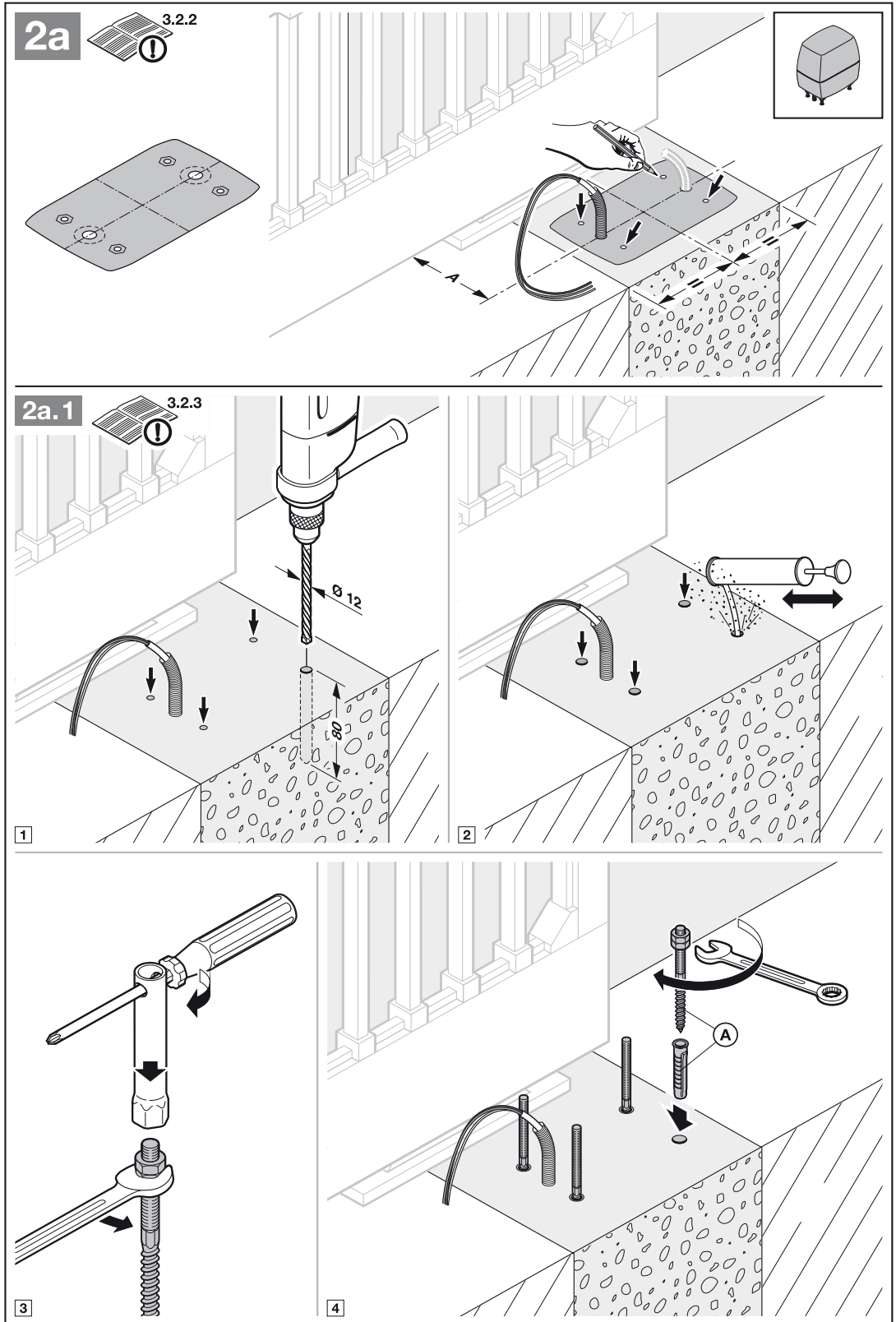

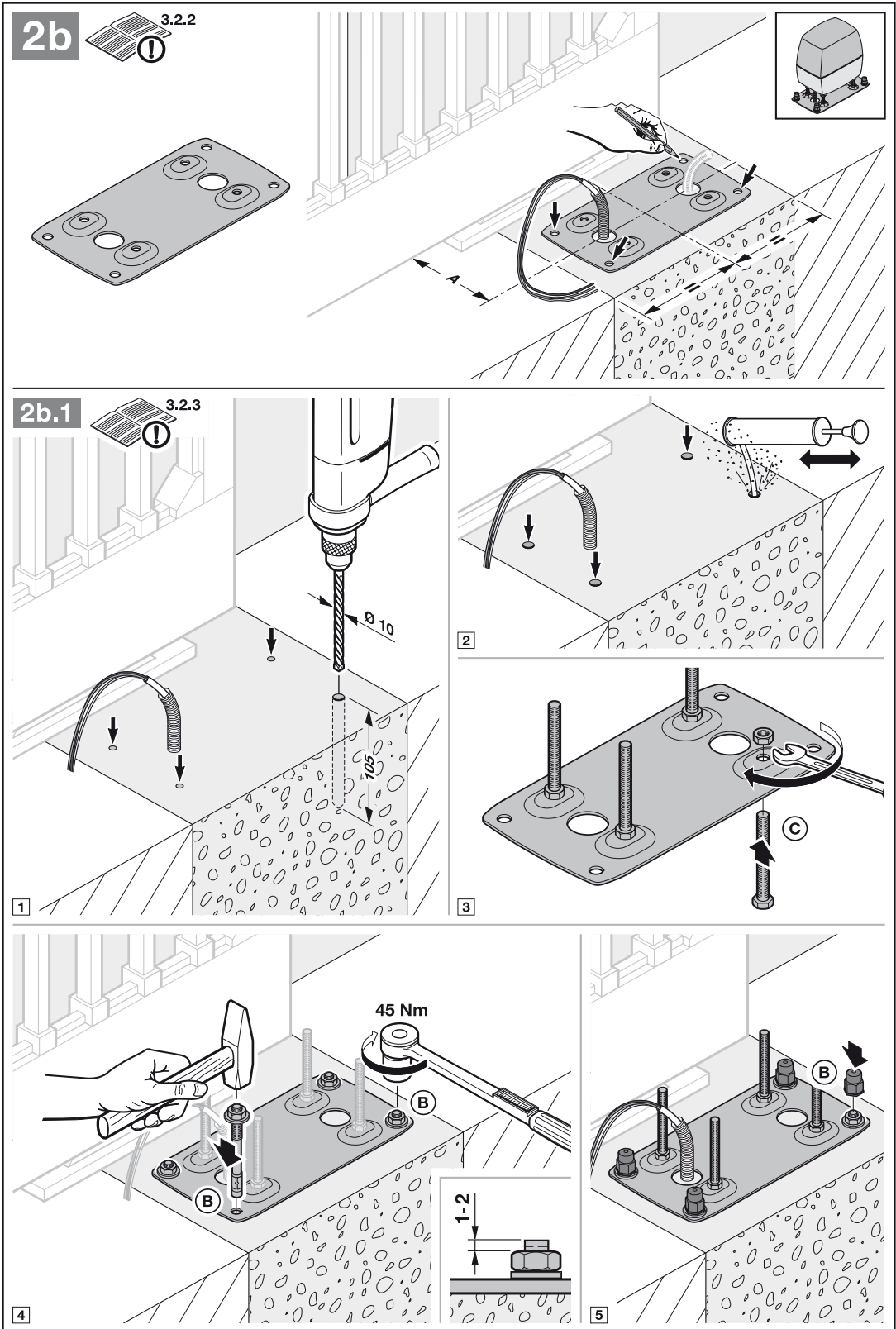

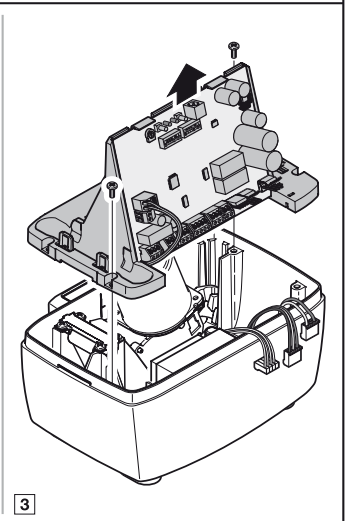
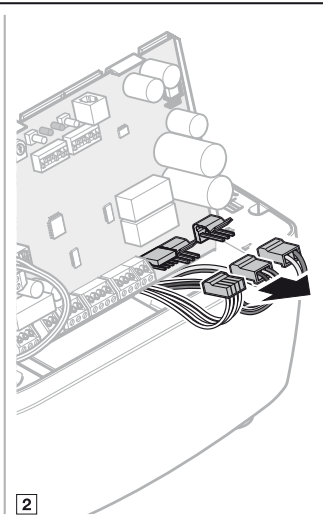
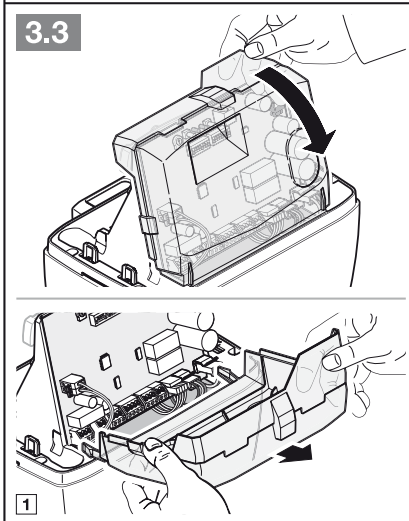
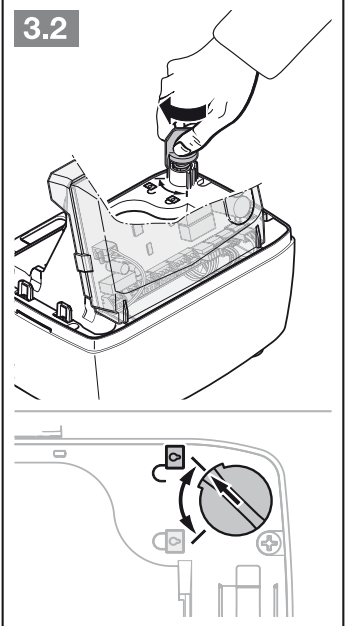
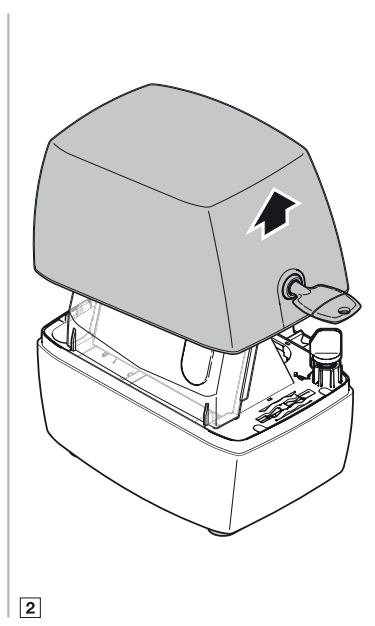
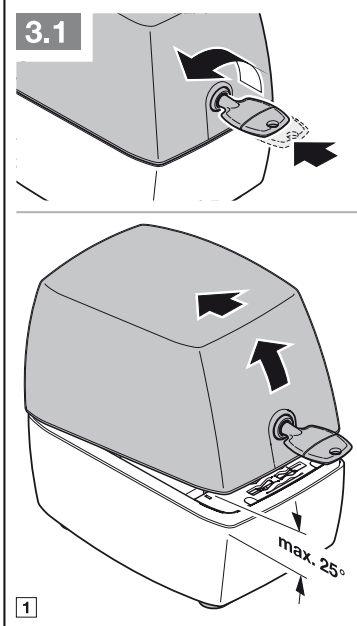
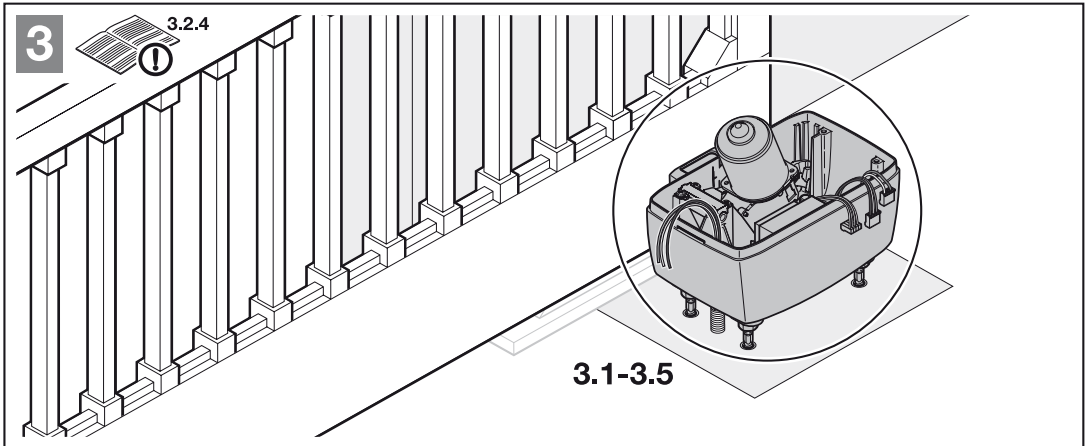

3.4

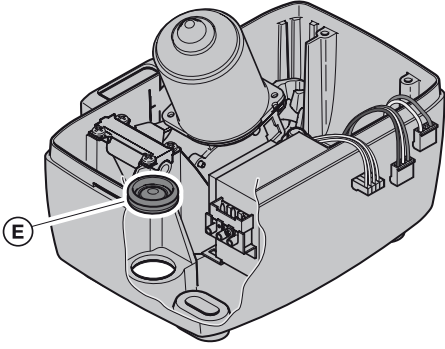

1

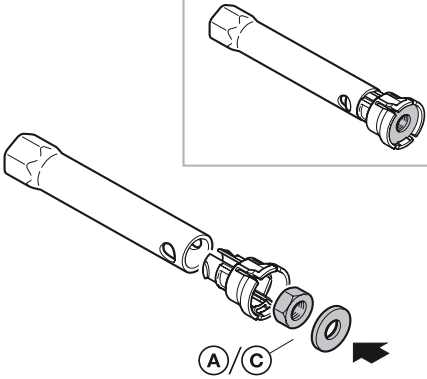

2

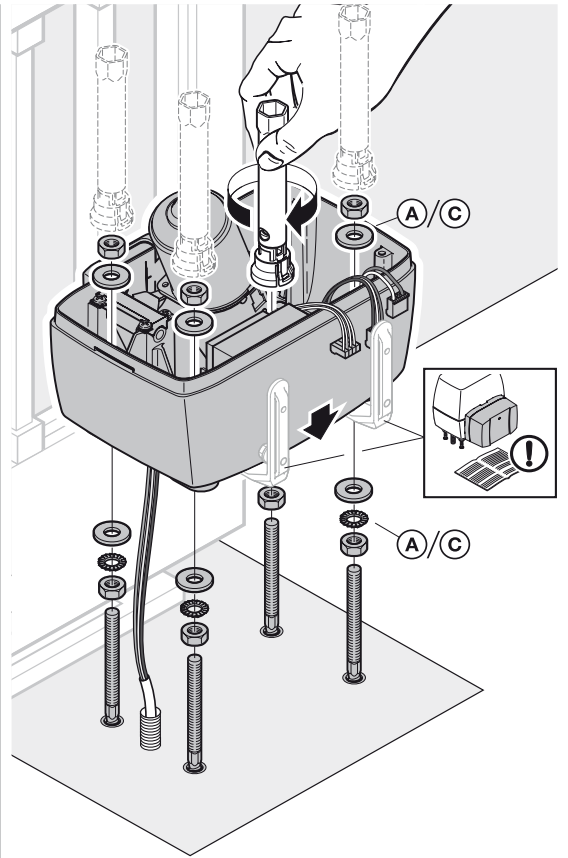

3

3.5

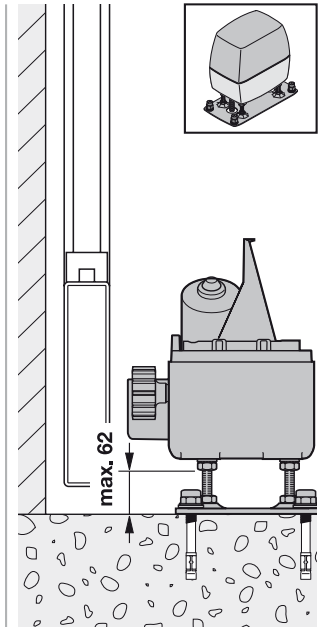
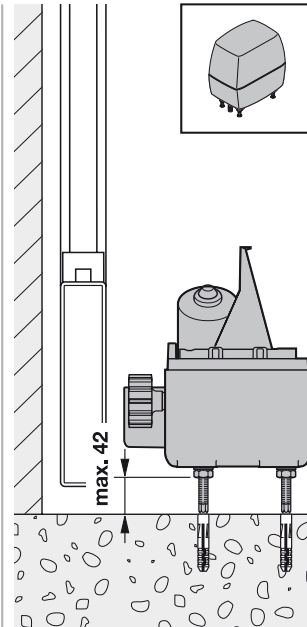
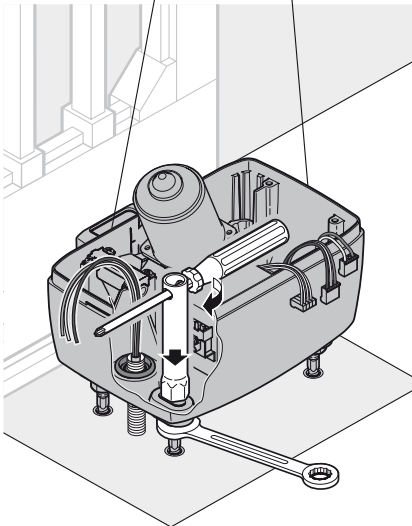

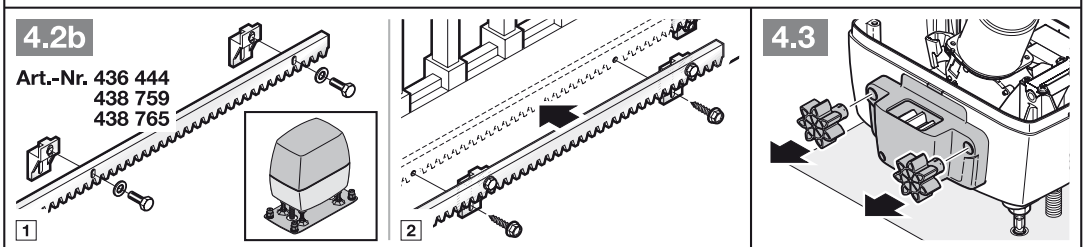
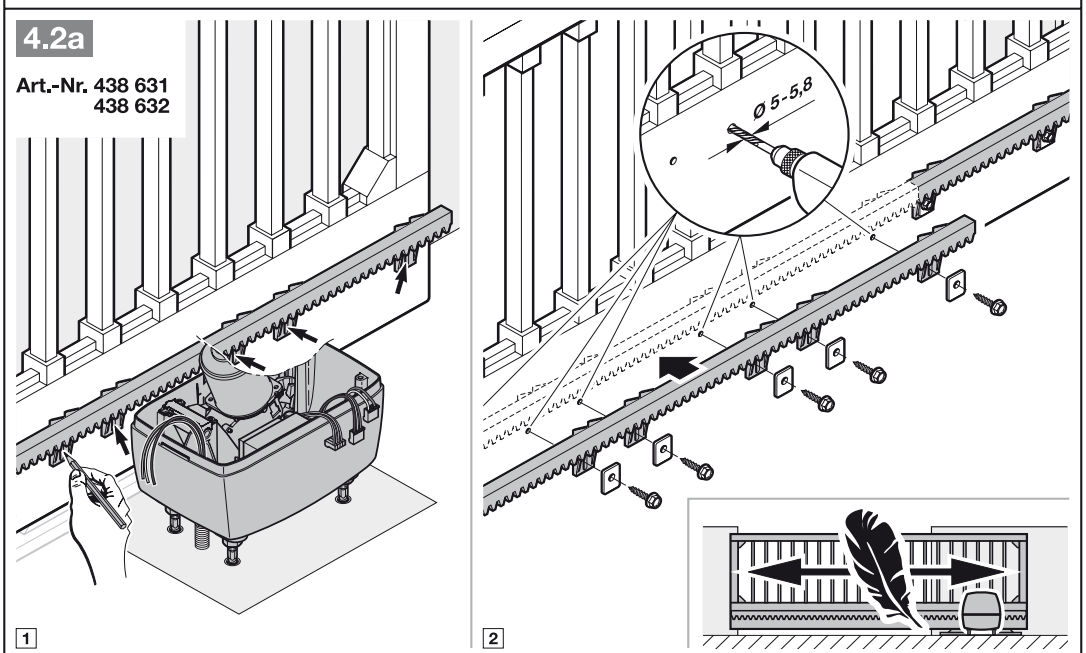
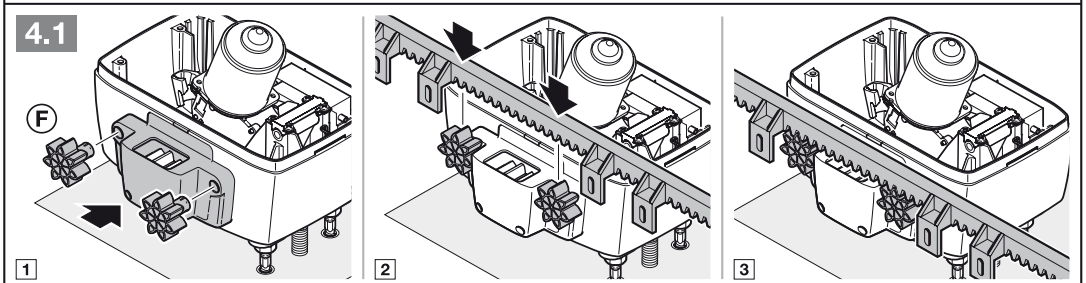
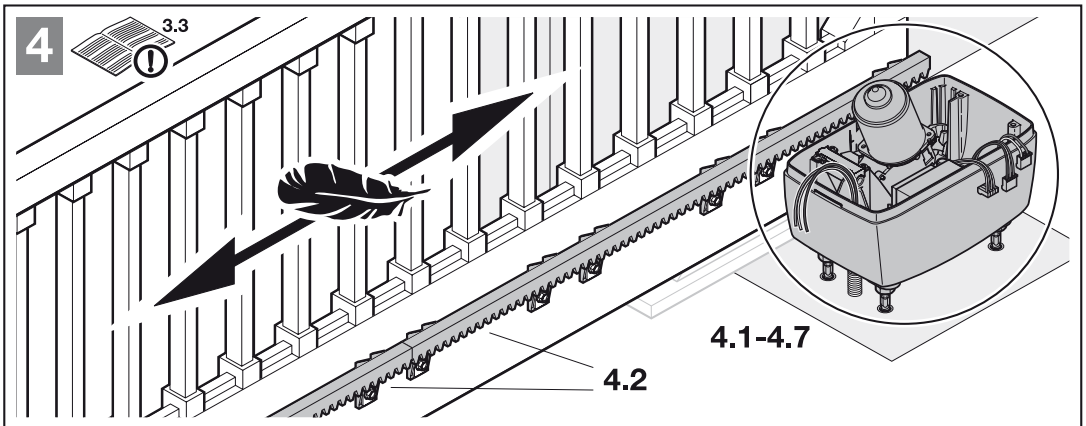



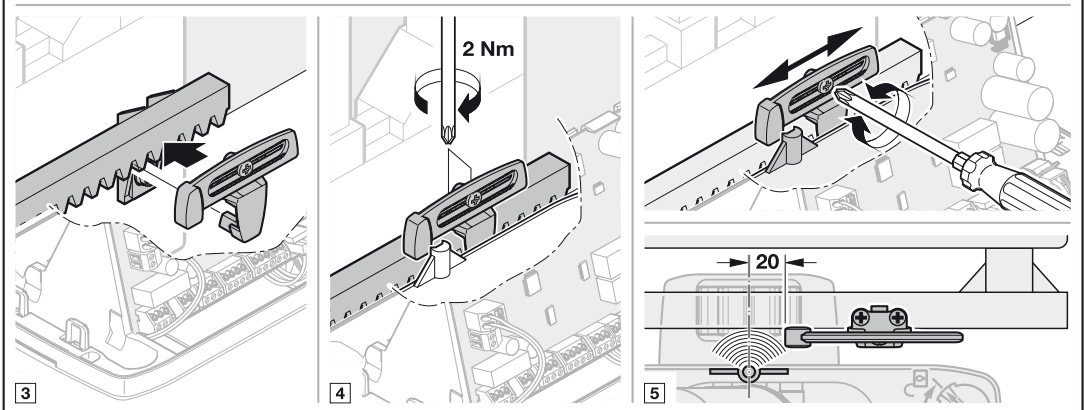
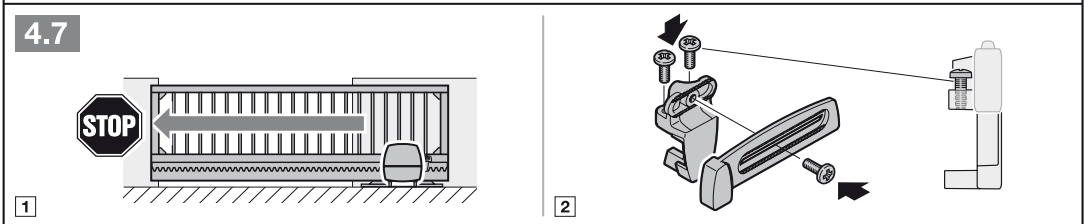
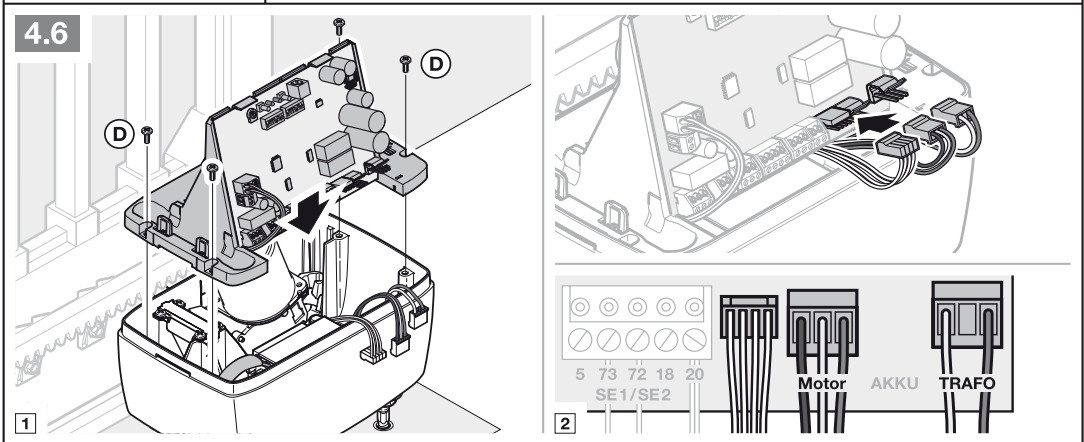
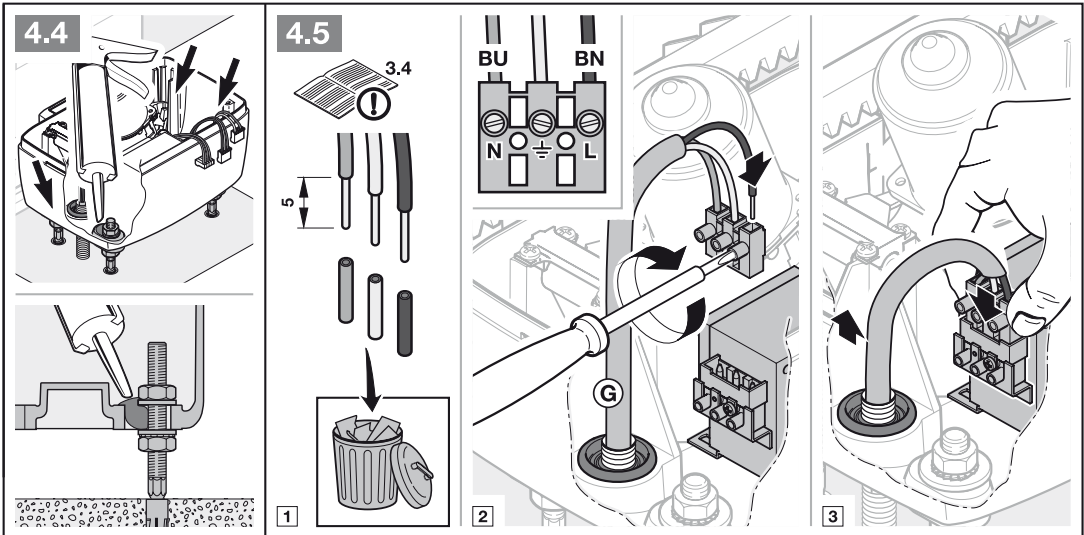

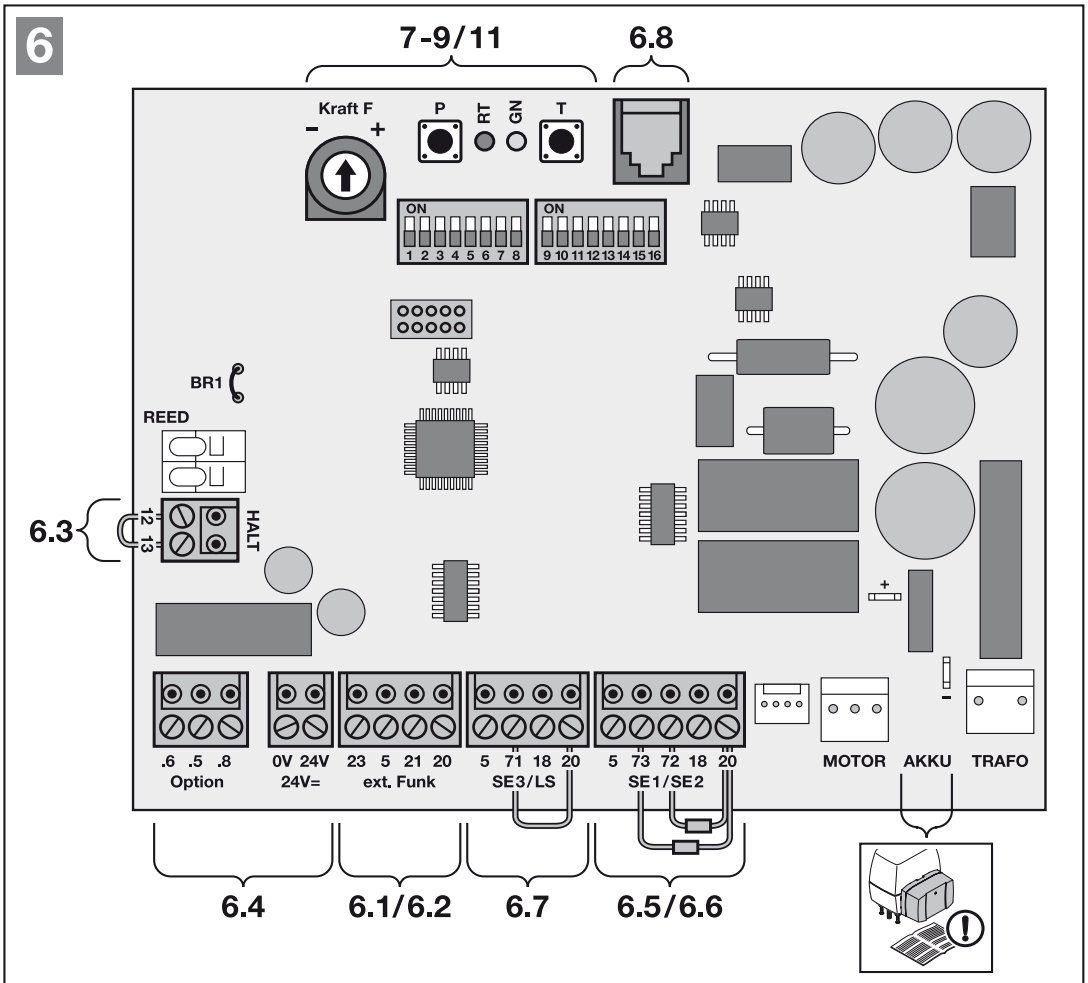
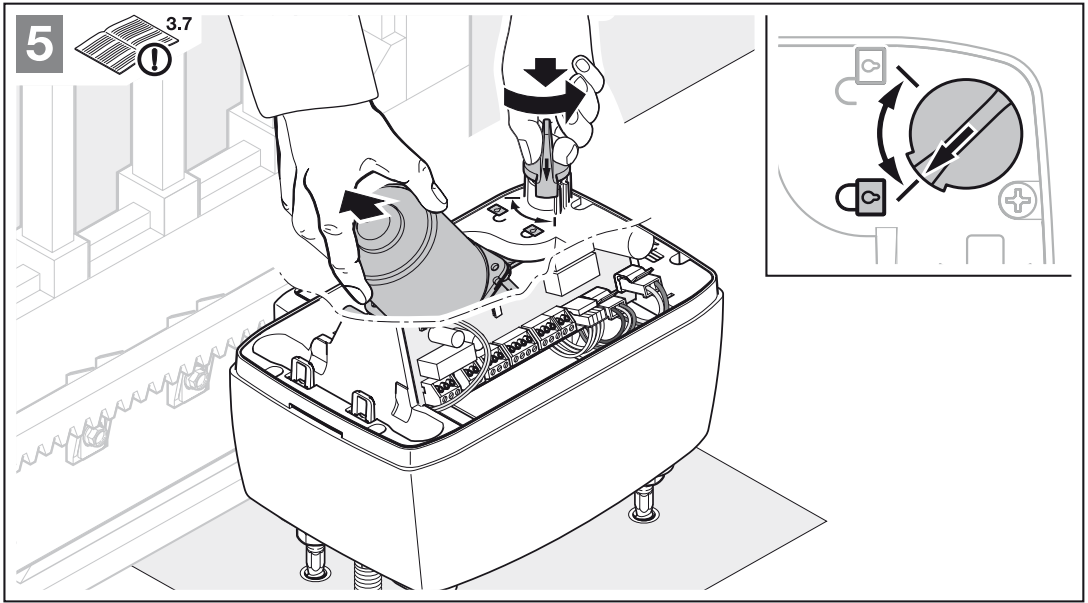



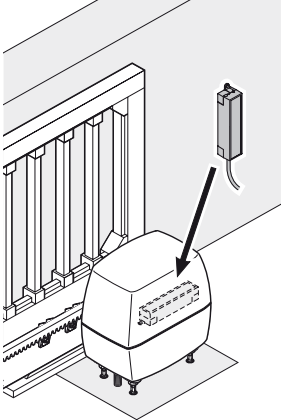
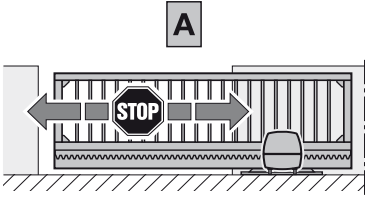
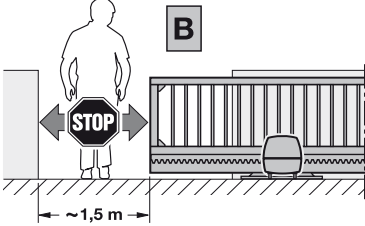
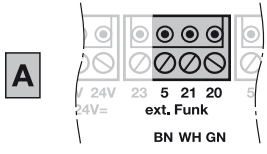
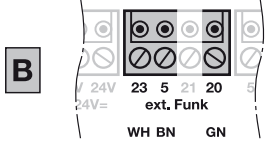
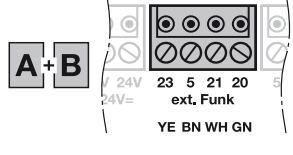

**6.1**  3.8.1/6.2.1

**6.2**  3.8.2

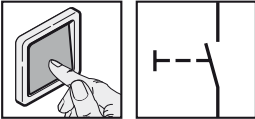
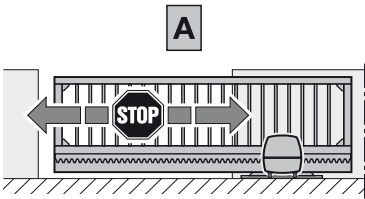
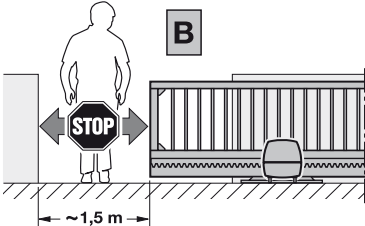
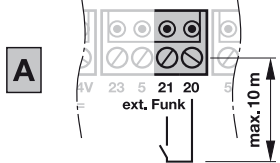
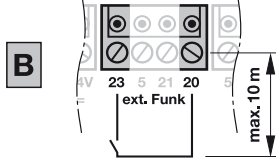
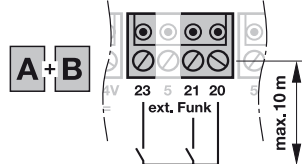





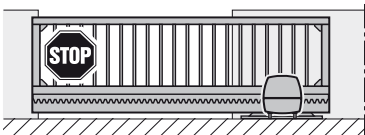
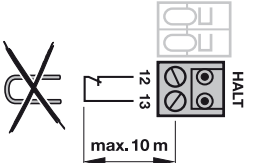

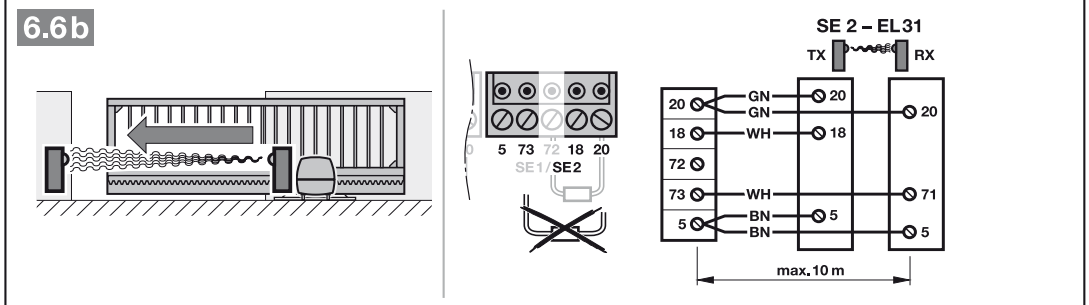
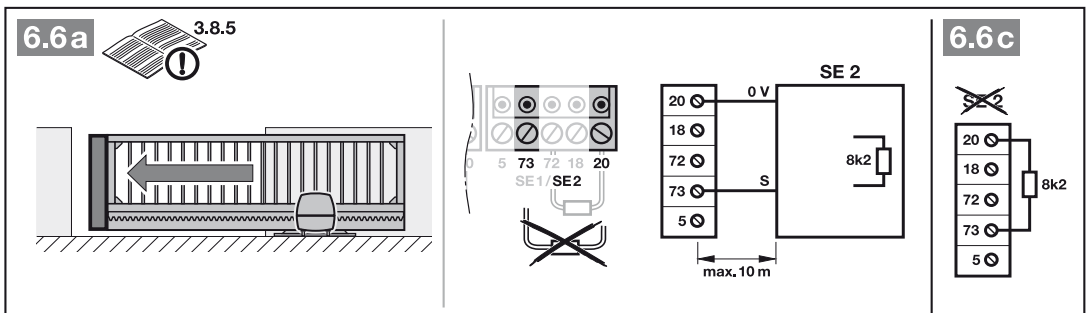
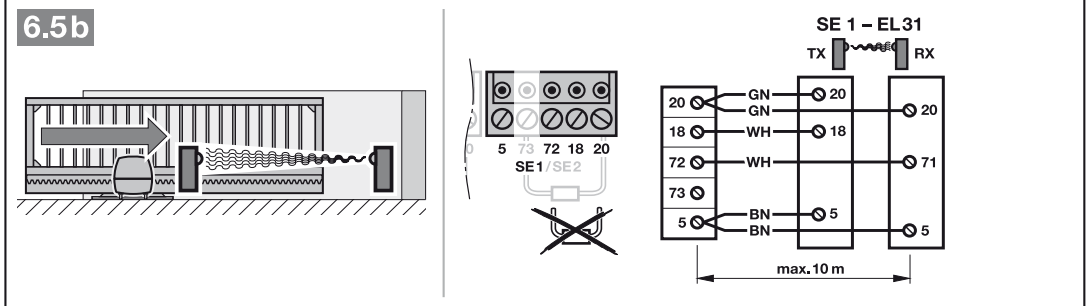
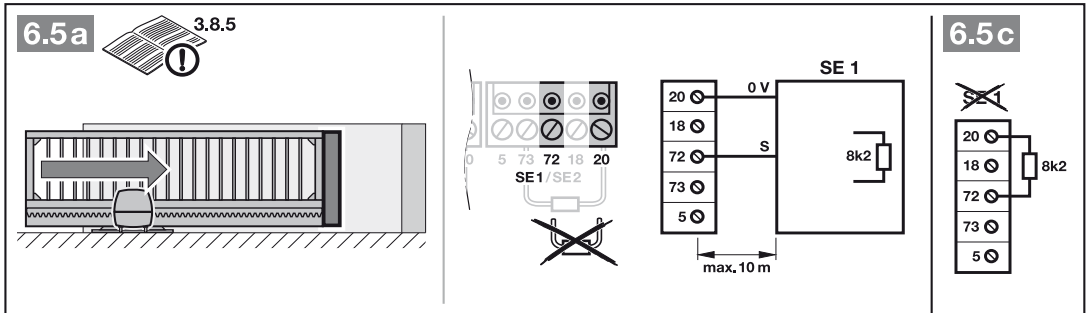
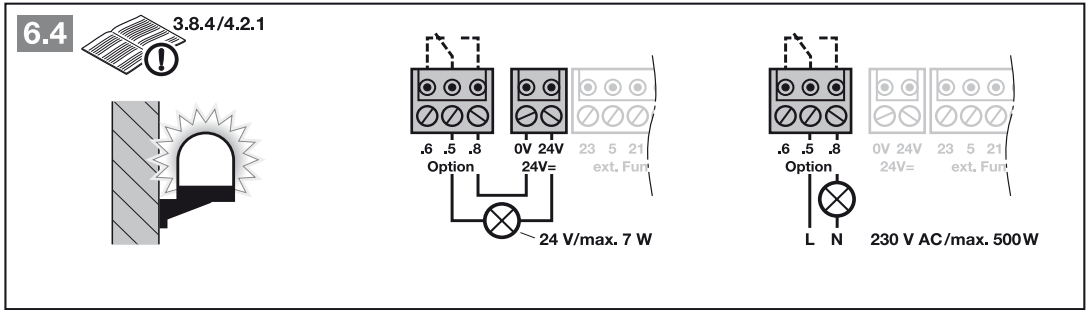
**6.3**  3.8.3

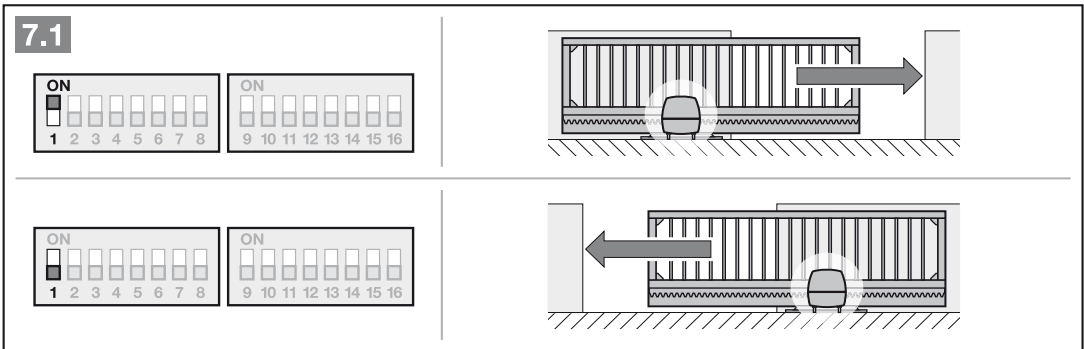
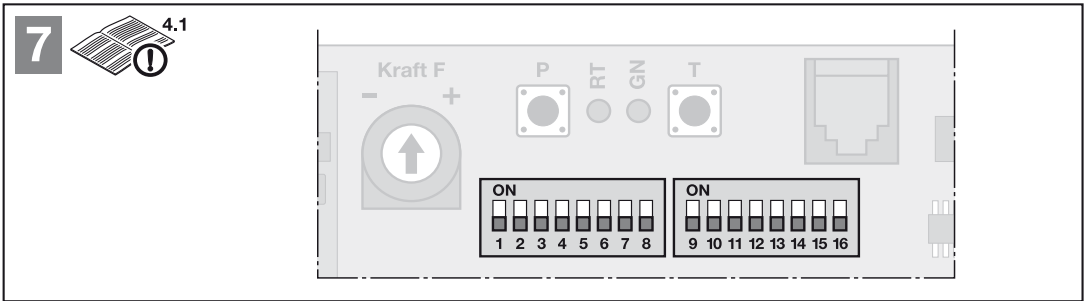
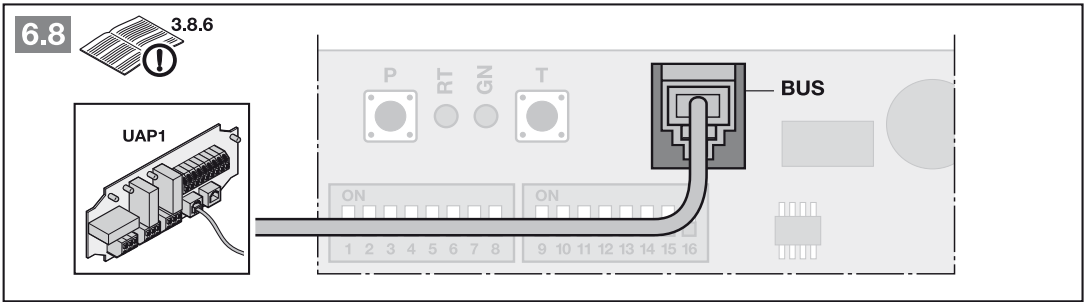
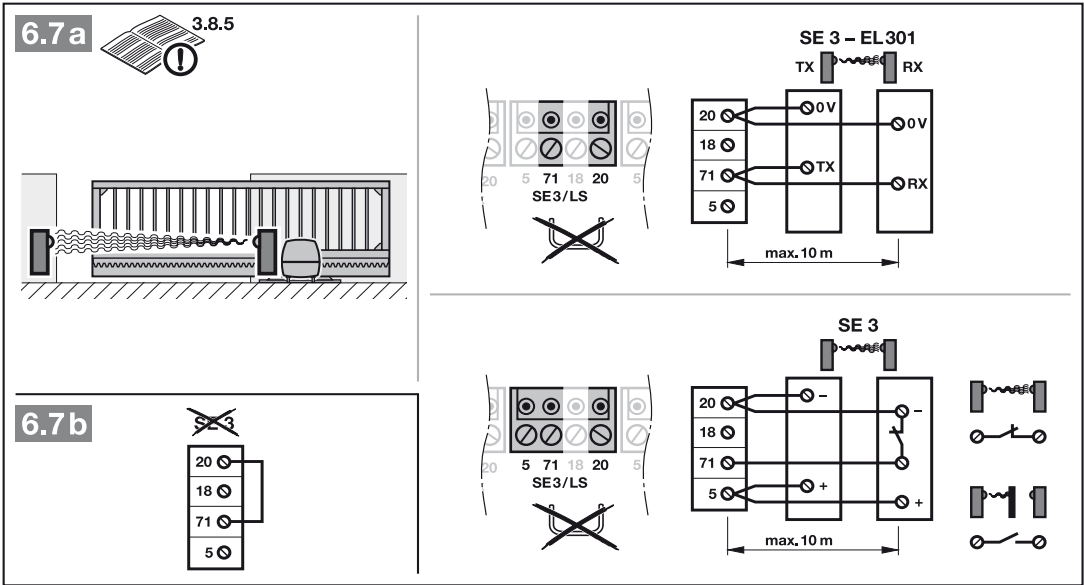







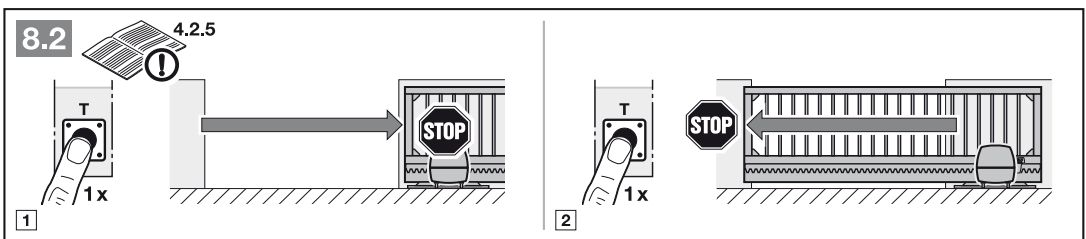
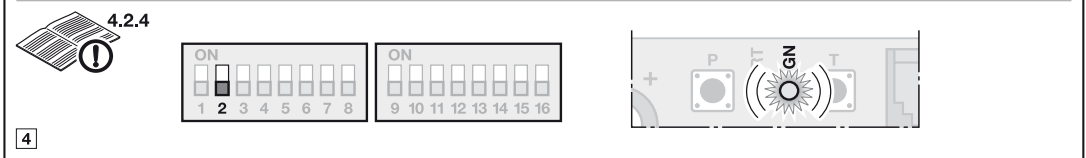
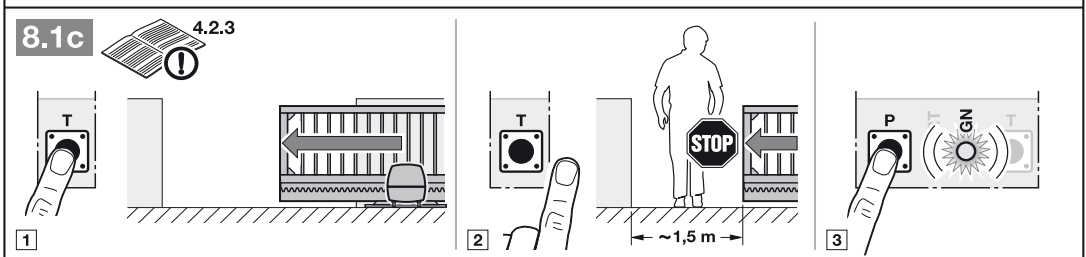
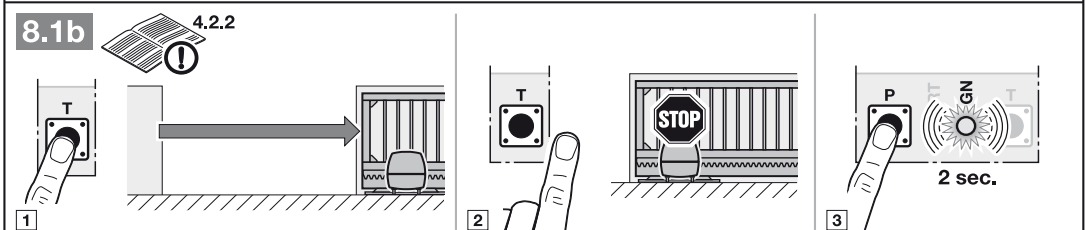
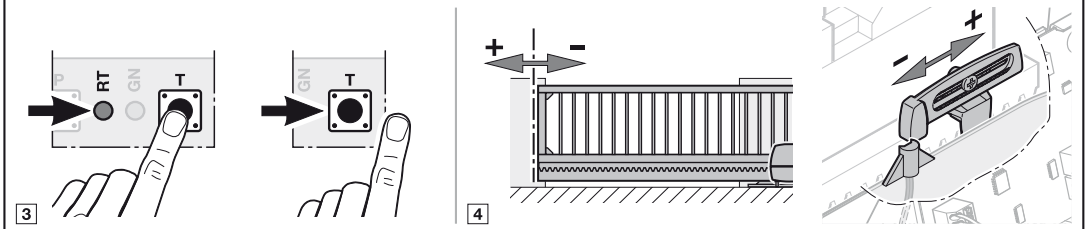
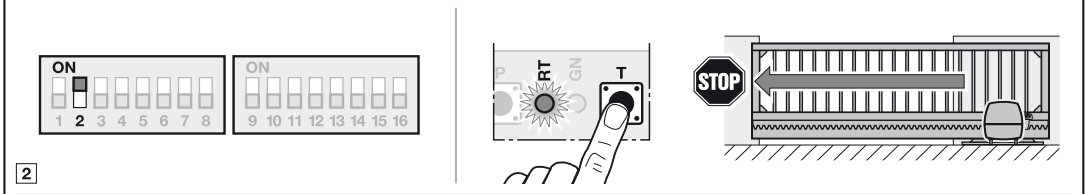
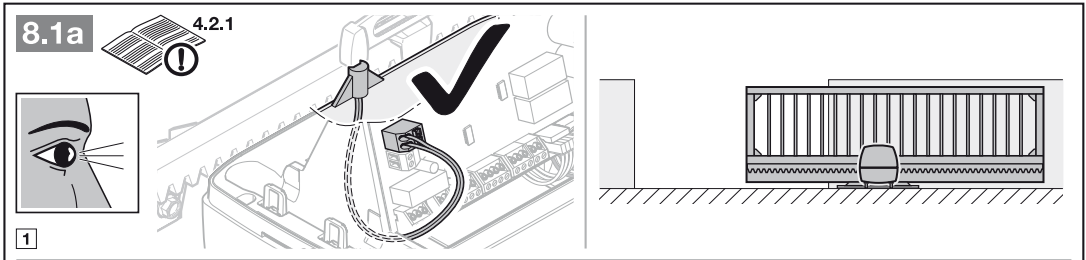

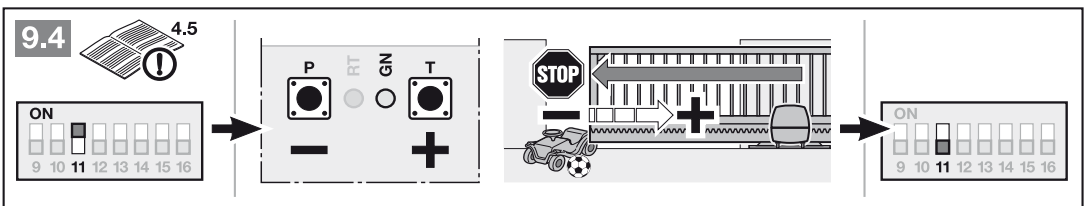
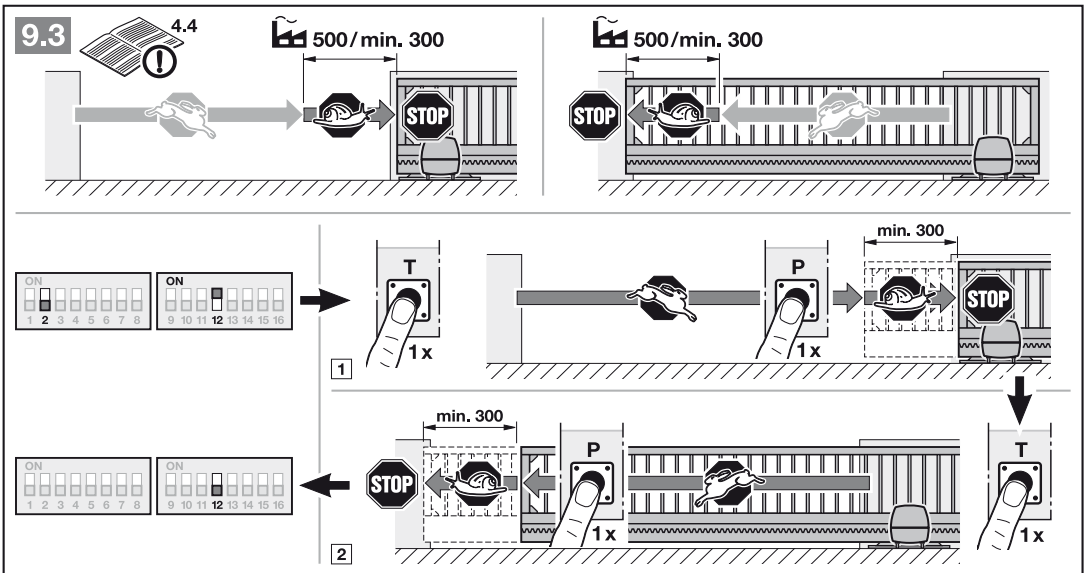
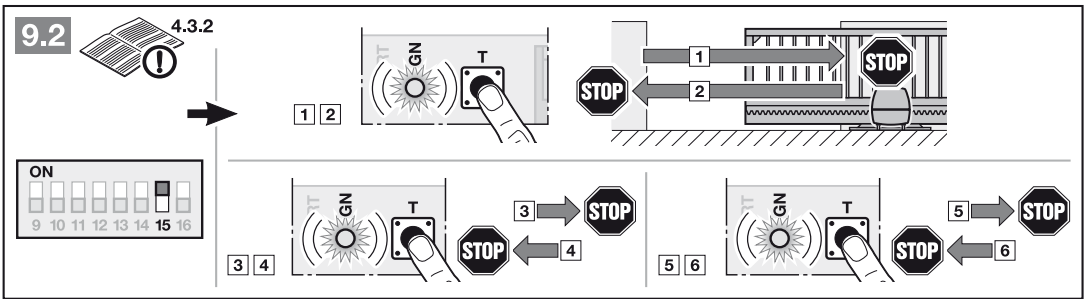
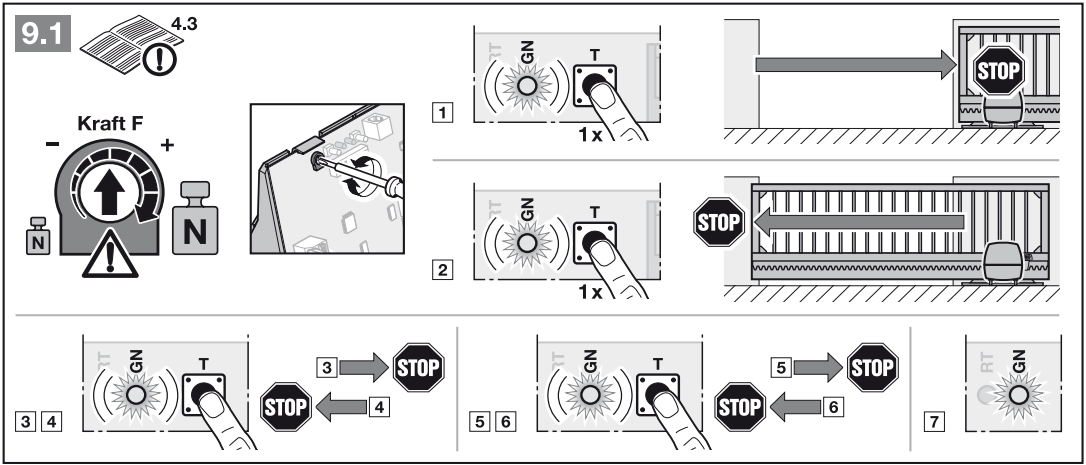





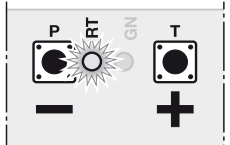

**9.5**  4.6



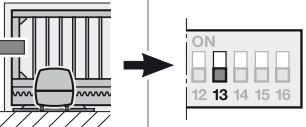



1x	30 sec.
2x	60 sec.
3x	90 sec.
4x	120 sec.
5x	180 sec.

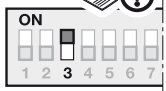

ON 12 13 14 15 16

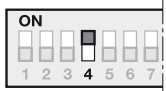
**9.6**  5.3

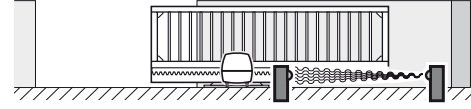
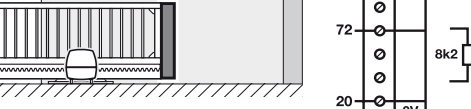
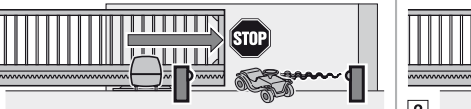
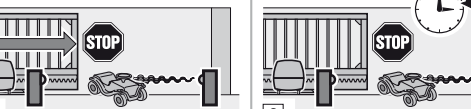
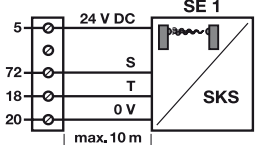
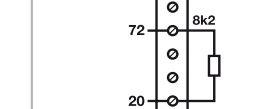
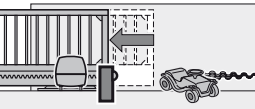
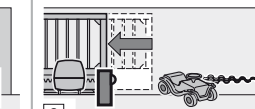
24 V DC SE 1

S

T

0 V

max. 10 m

8k2

8k2

STOP

1



2

1

2

3

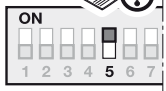
**9.7**  5.4

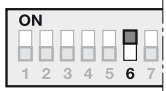
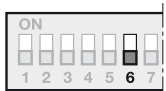
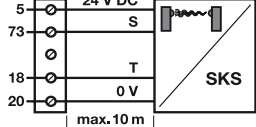
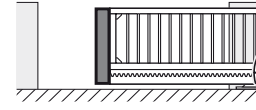
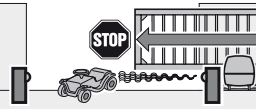
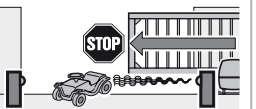
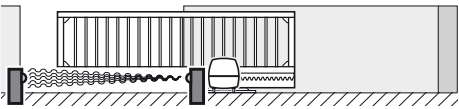
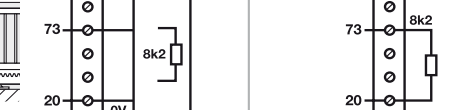
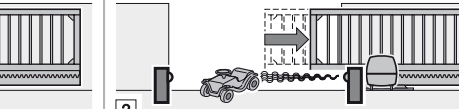
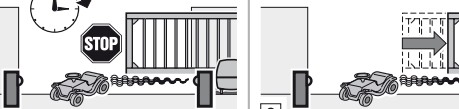
24 V DC SE 2

S

T

0 V

max. 10 m

8k2

8k2

STOP

1

2

1

2

3

**9.8** 5.5

ON 1 2 3 4 5 6 7 8

ON 1 2 3 4 5 6 7 8

71 S 20 0V max. 10 m SE 3

5 71 20 24 V DC S SE 3 max. 10 m

1 2 3

**9.9a** 5.6

ON 6 7 8 ON 9 10 11

ON 6 7 8 ON 9 10 11

1 2 3

**9.9b**

ON 6 7 8 ON 9 10 11

ON 6 7 8 ON 9 10 11

1 2 3

**9.9c**

ON 6 7 8 ON 9 10 11

ON 6 7 8 ON 9 10 11

1 2 3

**9.9d**

ON 6 7 8 ON 9 10 11

STOP

.6 .5 .8 Option

**9.10** 5.7

ON 9 10 11 12 13 14 15 16

ON 9 10 11 12 13 14 15 16

1 2

1 2

